



2015 Food and Beverage Analysis Catalog

Instrumentation for Food Processing, Beverage Manufacturing,
Commercial Kitchens and Food Service



www.hannainst.com

We Design, Manufacture, Supply and Support All of Our Products.

360° Value

When you buy a Hanna product, you're not only buying the best value for your money, but you're also receiving the benefit of Hanna's unsurpassed customer service and post-sale technical support.

Quality

Our products are designed and manufactured under strict ISO 9001:2008 standards. Every instrument undergoes stringent quality control tests at different stages of manufacturing including 100% quality control checks just prior to shipment.

Certification

All Hanna products are in compliance with CE directives and our production facilities are ISO 9001:2008 certified.

Close to You

It is our policy to regularly participate in local trade shows and advertise our latest innovations in market specific magazines.

Worldwide Leader

With 60 offices in over 40 countries, Hanna dedicates itself to be a worldwide leader in service and selection.

Offering research grade quality at competitive prices, every Hanna office strives to work with each customer to develop a solution tailored to their needs, and within their budget.

Local Support

After you have made your investment, you should never feel uncertain about the support or technical service you will receive. Hanna develops relationships with its customers built on quality products with personal service and support.

24/7 Access

Visit us on the web at www.hannainst.com. There you can search for products, look up local office contacts, read the latest news from Hanna and download instruction manuals, MSDS and brochures.

HANNA is the largest family-owned manufacturer of analytical instrumentation in the world.

For over 35 years, HANNA has delivered fresh and innovative products to its customers.



Headquarters

Hanna's headquarters is located in Woonsocket, RI. This facility also houses our primary research and development center, global marketing and sales coordination, technical training facility as well as the primary sales and technical service office for the USA.

Hanna Instruments®, USA

Highland Industrial Park
584 Park East Drive,
Woonsocket, RI 02895

p: 877-MY-HANNA
(877-694-2662)

f: (401) 765-7575

e: sales@hannainst.com

w: www.hannainst.com

Hanna Design and Manufacturing

In a short time, Hanna has reached its target to produce all of its instrumentation in-house. Since the introduction of its industrial science park in Europe, the facility is equipped to support all phases of production such as product research and design, plastic injection molding, electronic assembly, glass blowing for electrodes, standards production and final assembly of product. Hanna oversees all aspects of its products from conception to the final quality check and packaging.

Hanna also produces the packaging for all product lines. Each package is carefully designed for safety and practicality. The in-house control of all research, design and production steps provides continual quality control at all phases to assure the highest level of quality. After continuous validation and testing, Hanna products undergo a final quality control before they are packaged and released to consumers.

In-house production affords Hanna the freedom to efficiently bring new and innovative products to market while continuously improving the quality and features of existing products for our customers.

ISO 9001:2008 Certified

These instruments are manufactured in our European state-of-the-art ISO 9001:2008 production facility and is CE compliant to EN 61326-1 and EN 61010-1 standards.

Contents

Ascorbic Acid	4	Nitrate.....	27
Alkalinity	4	Ozone	27
Bromide	4	pH.....	28–38
Calcium	4	ISE Solutions.....	39
Carbon Dioxide	5	Phosphate.....	39
Chloride	5	Potassium.....	40
Chlorine	6–7	Refractometers	41–42
Chlorine Dioxide.....	7	Sugar	41
COD (Chemical Oxygen Demand).....	8–9	Sodium Chloride	42
Conductivity/TDS.....	10–14	Sodium.....	43
Dissolved Oxygen	15–17	Sulfide.....	43
Honey Color	18	Sulfite.....	43
Hardness.....	19	Temperature	44–53
Humidity	20	Titration	54–62
Hydrogen Peroxide	21	Automatic Titration System	54
Hypochlorite	21	Titratable Acidity for Dairy.....	56
Iodide.....	21	Titratable Acidity for Fruit Juice.....	57
Iodine.....	21	Karl Fischer Volumetric for Moisture Determination....	58
Maple Syrup	22	Karl Fischer Coulometric for Moisture Determination...60	
Multiparameter	23–26	Autosampler	62
		Turbidity.....	63

Limited Warranty

Hanna products are manufactured in our ISO 9001:2008 facilities, meeting the highest quality standards in the industry. Hanna's high standards also apply should a product be returned due to defects in material or workmanship. Our extensive warranty extends up to five years on some products.

- **Limitations:** Warranted products may be returned for repair or replacement only at the discretion of Hanna. In some circumstances, remedy may constitute refund for the price paid for the product.

The warranty period commences from the original date of sale to the user when purchased from Hanna Instruments, USA. Warranty is valid only when the product is used under normal conditions and in accordance with operating limitations and prescribed maintenance procedures. The express warranty stated previously is the only express warranty given by Hanna to the end-user buyer. Hanna expressly disclaims any warranties implied by law, including but not limited to warranty of merchantability of fitness for a particular purpose. Hanna shall not be liable for any individual or consequential damages of any kind for breach of any warranty, negligence, on the basis of strict liability or otherwise. Hanna's warranty periods differ across our range of instrumentation, please visit us on the web at: www.hannainst.com or contact your local Hanna representative for specific warranty information.

HI3850 Ascorbic Acid Test Kit



Specifications

Method	titration
Range	10-200 mg/L (ppm)
Smallest Increment	10 mg/L (ppm)
Chemical Method	iodometric
# Tests	100 avg.

Ordering Information

HI 3850 test kit comes with 100 mL ascorbic acid reagent A, 25 mL starch indicator, 100 mL ascorbic acid reagent C, 50 mL calibrated plastic vessels (2), 3 mL plastic pipette, 1 mL plastic pipette (2) and graduated plastic test tube with cap.

HI3811 Alkalinity Test Kit

Alkalinity (as CaCO₃) Phenolphthalein and Total



Specifications

Method	titration
Range	0-100 mg/L (ppm) 0-300 mg/L (ppm)
Smallest Increment	1 mg/L (ppm)/3 mg/L (ppm)
Chemical Method	phenolphthalein/bromphenol blue
# Tests	110 avg.

Ordering Information

HI3811 test kit comes with 10 mL phenolphthalein indicator, 10 mL bromophenol blue indicator, 120 mL alkalinity titrant, 10 mL calibrated vessel, 50 mL calibrated vessel, and calibrated syringe with tip.

HI4102 Bromide Ion Selective Electrode

For use with compatible ISE meters

- See a complete list of ISE Solutions on p. 39

Specifications

Type	solid-state; combination
Measurement Range	1M to 1X 10 ⁻⁶ M 79910 to 0.08 mg/L (ppm)
Optimum pH Range	2 to 12.5
Temperature Range	0 to 80°C
Approximate Slope	-56 mV
Body O.D.	12 mm
Insertion Length	120 mm
Body Material	PEI
Cable	1 m coaxial
Connection	BNC

Ordering Information

HI4102 solid-state; combination ISE with 1m coaxial cable and BNC connection



 Parameter Highlight

Ascorbic Acid

Vitamins are a necessity in order for humans to maintain good health. For example vitamin C, also known as ascorbic acid, is an antioxidant which is helpful in preventing tissue damage, as well as improving immune system health. Many citrus juices are a significant source of ascorbic acid, which is an essential vitamin not naturally produced by humans. As a result, citrus products are commonly incorporated into human diets in order to achieve the 75-120 mg per day recommended value for vitamin C. Since ascorbic acid is a reducing agent, the amount of ascorbic acid in juices may be measured through an iodometric titration either by chemical test kit or automatic titration (see HI 902C, p. 54).

HI 4104 Calcium Ion Selective Electrode

For use with compatible ISE meters

- See a complete list of ISE Solutions on p. 39

Specifications

Type	polymer membrane; combination
Measurement Range	1M to 3X 10 ⁻⁶ M 40080 to 0.12 mg/L (ppm)
Optimum pH Range	4 to 10
Temperature Range	0 to 40°C
Approximate Slope	+28 mV
Body O.D.	12 mm
Insertion Length	120 mm
Body Material	PEI/PVC
Cable	1 m coaxial
Connection	BNC

Ordering Information

HI4104 polymer membrane; combination ISE with 1m coaxial cable and BNC connection



HI4105 Carbon Dioxide Ion Selective Electrode

For use with compatible
ISE meters

- See a complete list of ISE Solutions on p. 39

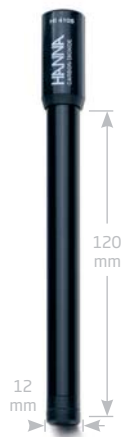

Specifications

Type	gas-sensing; combination
Measurement Range	1X10 ⁻² M to 1X10 ⁻⁴ M 440 to 4.4 mg/L (ppm)
Optimum pH Range	4.2 to 5.2
Temperature Range	0 to 40°C
Approximate Slope	+54 mV
Body O.D.	12 mm
Insertion Length	120 mm
Body Material	Delrin
Cable	1 m coaxial
Connection	BNC

Ordering Information

HI4105 gas-sensing; combination ISE with 1m coaxial cable and BNC connection

HI4107 Chloride Ion Selective Electrode

For use with compatible
ISE meters

- See a complete list of ISE Solutions on p. 39



Specifications

Type	solid-state; combination
Measurement Range	1M to 5X10 ⁻⁴ M 35000 to 1.8 mg/L (ppm)
Optimum pH Range	2 to 11
Temperature Range	0 to 80°C
Approximate Slope	-56 mV
Body O.D.	12 mm
Insertion Length	120 mm
Body Material	PEI
Cable	1 m coaxial
Connection	BNC

Ordering Information

HI4107 solid-state; combination ISE with 1m coaxial cable and BNC connection



Parameter Highlight

Calcium

Daily consumption of calcium helps to support a variety of functions within the human body, from heart health to bone density. Calcium can be sourced from food, vitamins, and supplements. Characteristically, dairy products, such as milk, yogurt, and cheese, contain the highest amounts of naturally based calcium per serving size when compared across all food groups. Other food products, such as orange juice and tofu may be fortified with calcium, where calcium is added during production from a synthetic source. For reporting and labeling requirements, calcium may need to be measured and recorded so that the customer is aware of the amount of calcium consumed per serving size. The calcium ion-selective electrode (ISE) provides an accurate and reliable way to measure calcium in a variety of food products. Equipped with an organic polymer sensing membrane, the calcium ISE is sensitive to free calcium ions dissolved in solution. The calcium ISE comes as either a half-cell design, where the sensing and reference electrodes are in two separate electrodes, or as a combination with both sensing and reference housed in one body. Both come equipped with an exchangeable sensing membrane that can be easily replaced when needed.

HI3815 Chloride Test Kit (as Cl⁻)



Specifications

Method	titration
Range	0-100 mg/L (ppm) 0-1000 mg/L (ppm)
Smallest Increment	1 mg/L (ppm)/10 mg/L (ppm)
Chemical Method	mercuric nitrate
# Tests	110 avg.

Ordering Information

HI3815 test kit comes with 15 mL diphenyl-carbazone indicator, 30 mL nitric acid solution, 120 mL mercuric nitrate solution, 50 mL calibrated vessel, 10 mL calibrated vessel, calibrated syringe with tip.

HI38015 Chloride Test Kit (as Cl⁻)



Specifications

Method	titration
Range	500-10000 mg/L (ppm) 5000-100000 mg/L (ppm)
Smallest Increment	100 mg/L (ppm)/1000 mg/L (ppm)
Chemical Method	silver nitrate
# Tests	100 avg.

Ordering Information

HI38015 test kit comes with 100 mL chloride reagent A, 25 mL chloride reagent B (2), 100 mL chloride reagent C, demineralizer bottle with filter cap for 12 L, 50 mL calibrated plastic vessel with cap, 3 mL plastic pipette, 1 mL plastic pipette, 1 mL syringes with tips (2) and brush.



 Application Note

Disinfection

Removal of microbial contamination is essential in food production. In order to ensure the area and materials that come in contact with food are properly sanitized, surfaces are first cleaned and then disinfected. Cleaning removes most of the microbial contamination, but it is the act of disinfection that further reduces the surface population of microorganisms that can contaminate machinery and food products. The food industry limits the types of disinfectants that can be utilized based upon toxicity. If conditions allow, high temperature water, or steam, is the disinfectant of choice due to its non-corrosive, non-selective and non-residual nature. However, with open surfaces, high temperature-based disinfection is not always feasible, in which case chlorine releasing compounds, ozone and surfactants are most often used.

Disinfectant efficiency is affected by a variety of factors, such as interfering substances, pH, concentration and contact time. Certain disinfectants, such as chlorine-releasing compounds (i.e. sodium hypochlorite, or "bleach") are highly pH dependent and therefore require pH to be monitored during the disinfection process. Ideally for chlorine disinfection, the pH should be between 6.5 and 7.0 to ensure the disinfectant is sufficiently sanitizing. In cases where the disinfectant is an oxidizer, such as ozone and chlorine, oxidation-reduction potential (ORP) is monitored to determine the oxidizing potential of the solution; the mV reading produced during the measurement will increase as the oxidizing potential increases. By using ORP values in conjunction with disinfectant concentration, the operator can ensure that the compound is in an effective form and is in large enough concentrations.

Various methods for measuring the disinfectant concentration are available including colorimetric tests for chlorine (free and total), ozone (low levels), anionic surfactants, iodine, and bromine.

HI96711C Chlorine, Free and Total Portable Photometer

- CAL Check™
- BEPS (Battery Error Prevention System)
- GLP Features



Specifications

Range	0.00 to 5.00 mg/L (ppm)
Resolution	0.01 mg/L from 0.00 to 3.50 mg/L (ppm); 0.10 mg/L above 3.50 mg/L (ppm)
Accuracy @ 25°C (77°F)	±0.03 mg/L ±3% of reading
Method	adaptation of the USEPA method 330.5 and Standard Method 4500-CIG

Ordering Information

HI96711C includes photometer, CAL Check™ standards, sample cuvettes (2) with caps, 9V battery, scissors, cuvette cleaning cloth, instrument quality certificate, instruction manual and rigid carrying case.
Reagents sold separately.

Reagents and Standards

HI96701-11	CAL Check™ standard cuvettes
HI93701-01	reagents for 100 tests
HI93701-03	reagents for 300 tests
HI96711-11	CAL Check™ standard cuvettes
HI93711-01	reagents for 100 tests
HI93711-03	reagents for 300 tests

Free & Total Chlorine Test Kits

HI38017
Low and Medium Range
with Checker Disc

HI38020
Low, Medium and High Range
with Checker Disc



Specifications

	HI38017	HI38020
Method	checker disc	checker disc
Range	0.00-0.70 mg/L (ppm) 0.0-3.5 mg/L (ppm)	0.00-0.70 mg/L (ppm) 0.0-3.5 mg/L (ppm) 0.0-10.0 mg/L (ppm)
Smallest Increment	0.02 mg/L (ppm) 0.1 mg/L (ppm)	0.02 mg/L (ppm) 0.1 mg/L (ppm) 0.5 mg/L (ppm)
Chemical Method	DPD	DPD
# Tests	200	200

Ordering Information

HI38017 and **HI38020** test kits come with HI93701-0 free chlorine reagent (100 packets), HI93711-0 total chlorine reagent (100 packets), demineralizer bottle with filter cap for 12 L, checker disc, glass vials with caps (2) and 3 mL plastic pipettes

HI96701C Free Chlorine Portable Photometer

- CAL Check™
- BEPS (Battery Error Prevention System)
- GLP Features



Specifications

Range	0.00 to 5.00 mg/L (ppm)						
Resolution	0.01 mg/L from 0.00 to 3.50 mg/L (ppm); 0.10 mg/L above 3.50 mg/L (ppm)						
Accuracy @ 25°C (77°F)	±0.03 mg/L ±3% of reading						
Method	adaptation of the USEPA method 330.5 and Standard Method 4500-Cl G						
Ordering Information	HI96701C includes photometer, CAL Check™ standards, sample cuvettes (2) with caps, 9V battery, cuvette cleaning cloth, instrument quality certificate, instruction manual and rigid carrying case. Reagents sold separately						
Reagents and Standards	<table border="1"> <tr> <td>HI96701-11</td> <td>CAL Check™ Standard Cuvettes</td> </tr> <tr> <td>HI93701-01</td> <td>reagents for 100 tests</td> </tr> <tr> <td>HI93701-03</td> <td>reagents for 300 tests</td> </tr> </table>	HI96701-11	CAL Check™ Standard Cuvettes	HI93701-01	reagents for 100 tests	HI93701-03	reagents for 300 tests
HI96701-11	CAL Check™ Standard Cuvettes						
HI93701-01	reagents for 100 tests						
HI93701-03	reagents for 300 tests						

Free Chlorine Test Kits

HI3831F
with color cube

HI3875
Medium Range with
Checker Disc

HI38018
Low and Medium
Range with Checker Disc



3831F Chlorine

Specifications	HI3831F	HI3875	HI38018
Method	colorimetric	checker disc	checker disc
Range*	0.0-2.5 mg/L (ppm)	0.0-3.5 mg/L (ppm)	0.00-0.70 mg/L (ppm) 0.0-3.5 mg/L (ppm)
Smallest Increment	0.5 mg/L (ppm)	0.1 mg/L (ppm)	0.02 mg/L (ppm) 0.1 mg/L (ppm)
Chemical Method	DPD	DPD	DPD
# Tests	50 avg.	100	200

Ordering Information

HI3831F test kit comes with color comparison cube, 20 mL reagent 1 and 15 mL reagent 2.
HI3875 test kit comes with HI93701-0 free Cl reagent (100 packets), 500 mL deionized water, checker disc, glass vials with caps (2) and 3 mL plastic pipette.
HI38018 test kit comes with HI93701-0 free chlorine reagent (200 packets), demineralizer bottle with cap for 12 L, checker disc, glass vials with caps (2) and 3 mL plastic pipettes.

HI96771C Free Chlorine Ultra HR Portable Photometer

- CAL Check™
- BEPS (Battery Error Prevention System)
- GLP Features
- Measures up to 500 ppm chlorine



HI96771C has been developed to check chlorine dosing in disinfection processes with ultra high concentrations of chlorine. This photometer is ideal for use in the food industry, such as in fruit and vegetable washing.

Specifications

Specifications	Free Chlorine (P1)	Chlorine, UHR (P2)
Range	0.00 to 5.00 mg/L (ppm)	0 to 500 mg/L (ppm)
Resolution	0.01 mg/L from 0.00 to 3.50 mg/L (ppm); 0.10 mg/L above 3.50 mg/L (ppm)	1 mg/L from 0 to 200 mg/L (ppm); 10 mg/L above 200 mg/L (ppm)
Accuracy @ 25°C (77°F)	±0.03 mg/L ±3% of reading	±3 mg/L ±3% of reading
Method	adaptation of Standard Methods for the Examination of Water and Wastewater, 20th edition, 4500-Cl	

Ordering Information

HI96771C includes photometer, CAL Check™ standards, sample cuvettes (2) with caps, 9V battery, scissors, cuvette cleaning cloth, instrument quality certificate, instruction manual and rigid carrying case. Reagents sold separately.

Reagents and Standards

HI93701-01	reagents for 100 tests (free chlorine)
HI93701-03	reagents for 300 tests (free chlorine)
HI95771-01	reagents for 100 tests (UHR chlorine)
HI95771-03	reagents for 300 tests (UHR chlorine)
HI96771-11	CAL Check™ Standards

HI96738 Chlorine Dioxide Portable Photometer



Specifications

Range	0.00 to 2.00 mg/L (ppm)
Resolution	0.01 mg/L (ppm)
Accuracy @ 25°C (77°F)	±0.10 mg/L ±5% of reading
Method	Chlorophenol Red method

Ordering Information

HI96738 is supplied with sample cuvettes (2) with caps, 9V battery, instrument quality certificate and instruction manual. CAL CHECK™ standards and testing reagents sold separately

Reagents and Accessories

HI96738-11	CAL Check™ standard cuvettes
HI93738-01	reagents for 100 tests
HI93738-03	reagents for 300 tests



HI83099 COD Meter and Multiparameter Photometer

- Easy COD measurement
- Outstanding measurement quality
- Compact, multiparameter meter
- PC compatible
- 47 methods

HI83099 is one of the most versatile photometers on the market. In addition to COD, this meter measures up to 47 (including COD) of the most important water quality parameters using liquid or powder reagents. The amount of reagent is precisely dosed to ensure maximum reproducibility.

HI83099 bench photometer can be connected to a PC via a USB cable. The optional HI92000 Windows® Compatible Software helps users manage their data.

HI83099 features a powerful interactive user support to assist the user during each step of the analysis process. A tutorial mode is also available in the Setup Menu.



Notes:
 † Method with chromium-sulfuric acid is officially recognized by EPA for wastewater analysis.
 ◊ The HI93754F-25 and HI93754G-25 method follows the official method ISO 15705.
 ◊◊ This method is recommended for general purpose analysis with no chloride interference.
 † 100 tests, replace the -01 with -03 for 300 tests.
 ** Reagents for 50 tests, replace -01 for -03 for 150 tests
 * For Chlorine, liquid reagents are available.

COD Test	Range	Method	Reagent Code
COD LR	0 to 150 mg/L (ppm)	dichromate EPA† dichromate mercury-free◊◊ dichromate ISO◊	HI93754A-25 HI93754D-25 HI93754F-25
COD MR	0 to 1500 mg/L (ppm)	dichromate EPA† dichromate mercury-free◊◊ dichromate ISO◊	HI93754B-25 HI93754E-25 HI93754G-25
COD HR	0 to 15000 mg/L (ppm)	dichromate	HI93754C-25

Water Quality Test	Range	Method	Reagent Code
Alkalinity	0 to 500 mg/L (ppm) as CaCO ₃	bromocresol green	HI93755-01 †
Aluminum	0.00 to 1.00 mg/L (ppm)	aluminon	HI93712-01 †
Ammonia MR	0.00 to 10.00 mg/L (ppm)	Nessler	HI93715-01 †
Ammonia LR	0.00 to 3.00 mg/L (ppm)	Nessler	HI93700-01 †
Bromine	0.00 to 8.00 mg/L (ppm)	DPD	HI93716-01 †
Calcium	0 to 400 mg/L (ppm)	oxalate	HI937521-01 **
Chlorine Dioxide	0.00 to 2.00 mg/L (ppm)	chlorophenol Red	HI93738-01 †
Chlorine*, Free	0.00 to 2.50 mg/L (ppm)	DPD	HI93701-01 †
Chlorine*, Total	0.00 to 3.50 mg/L (ppm)	DPD	HI93711-01 †
Chromium VI HR	0 to 1000 µg/L	diphenyl-carbohydrazide	HI93723-01 †
Chromium VI LR	0 to 300 µg/L	diphenyl-carbohydrazide	HI93749-01 †
Color of Water	0 to 500 PCU	colorimetric platinum cobalt	-
Copper HR	0.00 to 5.00 mg/L (ppm)	bicinchoninate	HI93702-01 †
Copper LR	0 to 1000 µg/L	bicinchoninate	HI95747-01 †
Cyanuric Acid	0 to 80 mg/L (ppm)	turbidimetric	HI93722-01 †
Fluoride	0.00 to 2.00 mg/L (ppm)	SPADNS	HI93729-01 †
Hardness, Calcium	0.00 to 2.70 mg/L (ppm)	calmagite	HI93720-01 †
Hardness, Magnesium	0.00 to 2.00 mg/L (ppm)	EDTA	HI93719-01 †
Hydrazine	0 to 400 µg/L	p-dimethyl-aminobenzaldehyde	HI93704-01 †
Iodine	0.0 to 12.5 mg/L (ppm)	DPD	HI93718-01 †
Iron HR	0.00 to 5.00 mg/L (ppm)	phenantroline	HI93721-01 †
Iron LR	0 to 400 µg/L	TPTZ	HI93746-01 **
Magnesium	0 to 150 mg/L (ppm)	calmagite	HI937520-01 **
Manganese HR	0.0 to 20.0 mg/L (ppm)	periodate	HI93709-01 †
Manganese LR	0 to 300 µg/L	PAN	HI93748-01 **
Molybdenum	0.0 to 40.0 mg/L (ppm)	mercaptoacetic acid	HI93730-01 †
Nickel HR	0.00 to 7.00 g/L	photometric	HI93726-01 †
Nickel LR	0.000 mg/L to 1.000 mg/L (ppm)	PAN	HI93740-01 **
Nitrate	0.0 to 30.0 mg/L (ppm)	cadmium reduction	HI93728-01 †
Nitrite HR	0 to 150 mg/L (ppm)	ferrous sulfate	HI93708-01 †
Nitrite LR	0.00 to 0.35 mg/L (ppm)	diazotization	HI93707-01 †
Oxygen, Dissolved (DO)	0.0 to 10.0 mg/L (ppm)	Winkler	HI93732-01 †
Ozone	0.00 to 2.00 mg/L (ppm)	DPD	HI93757-01 †
pH	6.5 to 8.5 pH	phenol red	HI93710-01 †
Phosphate HR	0.0 to 30.0 mg/L (ppm)	amino acid	HI93717-01 †
Phosphate LR	0.00 to 2.50 mg/L (ppm)	ascorbic acid	HI93713-01 †
Phosphorus	0.0 to 15.0 mg/L (ppm)	amino acid	HI93706-01 †
Potassium HR	20 to 200 mg/L (ppm)	turbidimetric tetraphenylborate	HI93750-01 †
Potassium MR	10 to 100 mg/L (ppm)	turbidimetric tetraphenylborate	HI93750-01 †
Potassium LR	0.0 to 20.0 mg/L (ppm)	turbidimetric tetraphenylborate	HI93750-01 †
Silica	0.00 to 2.00 mg/L (ppm)	heteropoly blue	HI93705-01 †
Silver	0.000 to 1.000 mg/L (ppm)	PAN	HI93737-01 **
Sulfate	0 to 150 mg/L (ppm)	turbidimetric	HI93751-01 †
Zinc	0.00 to 3.00 mg/L (ppm)	zincon	HI93731-01 †

Ordering Information

HI83099-01 (115V) is supplied with glass cuvettes (4), cell protective cap, batteries, 12 VDC adapter, sample preparation kit (for turbidity or concentrated samples), cloth for wiping cuvettes, 60mL glass bottle for DO analysis, scissors, and instructions.

HI839800 COD Test Tube Heater

with 25 Vial Capacity

- **Low and high temperature alerts**
 - Appears when the block is warming up and the temperature is above or below the set value.
- **Countdown timer**
 - Shows time remaining until the heating element shuts off.

The HI839800 COD reactor is an easy to use test tube heater. The reactor is equipped with two predefined temperature settings, 105°C and 150°C, where digestions are conducted at 150°C.

A three hour countdown timer is also incorporated to control timed digestions. When the countdown timer expires, a beep will sound and the heating element will turn off. The reactor contains a thermal fuse that prevents overheating by turning off the heating element.

Block temperature is continuously displayed on the LCD even when there is no active temperature program running. The aluminum block incorporates a 25-vial capacity and a well for a reference temperature probe.



HI740217
Lab Safety Shield



HI740216
Test Tube Cooling Rack

For safety, the optional HI740217 safety shield and HI740216 test tube cooling rack for the HI839800 are strongly recommended.



Outer casing stays cool to the touch!

Specifications	HI839800
Temperature of Reaction	105°C or 150°C (221°F or 302°F)
Temperature Stability	±0.5°C (±0.9°F)
Temperature Range	-10°C to 160°C (14°F to 320°F)
Accuracy	±2°C (±3.6°F)
Capacity	25 vials (dia 16 x 100 mm), one receptacle for a stainless steel reference thermometer
Warm-up Time	10-15 minutes, depending on selected temperature
Operating Mode	timed (0 to 180 minutes) or infinity mode
Block	aluminum
Ordering Information	HI839800-01 (115V) is supplied with power cable and instructions.

Certified COD Reagents



Hanna COD reagents are available in the following formats:

Code	Description	Method	Range
HI93754A-25	low range	EPA*	0 to 150 mg/L (ppm)
HI93754B-25	medium range	EPA*	0 to 1500 mg/L (ppm)
HI93754C-25	high range	EPA*	0 to 15000 mg/L (ppm)
HI93754D-25	low range	Mercury-free***	0 to 150 mg/L (ppm)
HI93754E-25	medium range	Mercury-free***	0 to 1500 mg/L (ppm)

Each box of 25 vials is supplied with a Hanna certificate of quality. The reagents are traceable to NIST SRM® 930. Hanna also produces mercury-free reagents to be used for analyzing samples without chloride.

Parameter Highlight

Chemical Oxygen Demand (COD)

Chemical Oxygen Demand (COD) is an important parameter measured in food processing wastewater. COD is measurement of the amount of oxygen necessary for chemical oxidation of organic compounds to occur. While COD measurements are typically used to indicate the strength and quality of the wastewater produced during the food manufacturing process, it can also indicate waste in manufacturing procedures.

The major constituents of food waste have a nutrient value, which contribute to high COD readings. Elevated levels of COD can result in organic overloading if wastewater from food processes is left untreated before discharged into a public sewer system. The National Pretreatment Program was established to regulate pollutant overloads within the sewer collection system and municipal wastewater treatment plants. Food processing plants that must comply with a pretreatment program are required to remove pollutants, including COD, from their wastewater prior to discharge.

Analysis of COD involves the use of a strong oxidizing agent, typically potassium dichromate. Hanna COD reagents are supplied as individual vials with pre-measured reagents to which the wastewater sample is added, eliminating the need for chemical handling and reagent additions. A 2 hour digestion is necessary for the oxidation to completely occur; after cooling, a photometer can be used to colorimetrically determine the COD value. Hanna offers a variety of COD reagents, including EPA-approved, which contains mercuric sulfate and needs to be safely disposed of. Hanna also offers ISO-approved and mercury-free reagents.

HI5321

Research Grade Conductivity/TDS Meter

EC/TDS/Resistivity/Salinity and Temperature

- Measures from ultra pure water to high levels of salinity
- Autoranging for EC, TDS and resistivity
- Up to four-point calibration
- Automatic or log-on-demand datalogging with 10,000 samples/lot
- PC compatible via USB with HI92000 software
- HI76312 platinum, four-ring conductivity/TDS probe with built-in temperature sensor included
- Outside measurement range and calibration reminders
- Capacitive touch keypad



Research Grade Conductivity Measurement

HI5321 is a research grade EC/Resistivity/TDS/Salinity benchtop meter with a large, color, graphic LCD with backlight, capable of millesimal measuring resolution. Conductivity can be measured within the range of 0.001 $\mu\text{S}/\text{cm}$ to 1 S/cm .

Conductivity is fully customizable and includes temperature compensation coefficient, temperature reference, selectable compensation method (linear, natural water and no compensation), adjustable cell constant and TDS factor.

Profiles

Up to 10 profiles can be saved and recalled, eliminating the need to reconfigure each time when a different electrode is used.

Additional Features

Features also include real-time graphic displays and on-screen GLP data. Fully customizable menu and parameters via setup screens. On-board contextual help can be accessed from any mode simply by pressing the HELP button.



Specifications

Conductivity	Range	0.000 to 9.999 $\mu\text{S}/\text{cm}$; 10.00 to 99.99 $\mu\text{S}/\text{cm}$; 100.0 to 999.9 $\mu\text{S}/\text{cm}$; 1.000 to 9.999 mS/cm ; 10.00 to 99.99 mS/cm ; 100.0 to 1000 mS/cm (actual EC) with temperature compensation disabled
	Resolution	0.001 $\mu\text{S}/\text{cm}$; 0.01 $\mu\text{S}/\text{cm}$; 0.1 $\mu\text{S}/\text{cm}$; 0.001 mS/cm ; 0.01 mS/cm ; 0.1 mS/cm
	Accuracy	$\pm 1\%$ of reading ($\pm 0.01 \mu\text{S}/\text{cm}$)
	Calibration	auto standard recognition, custom calibration solution/four-point calibration
TDS	Range	0.000 to 9.999 ppm; 10.00 to 99.99 ppm; 100.0 to 999.9 ppm; 1.000 to 9.999 ppt; 10.00 to 99.99 ppt; 100.0 to 400.0 ppt actual TDS (with 1.00 factor)
	Resolution	0.001 ppm; 0.01 ppm; 0.1 ppm; 0.001 ppt; 0.01 ppt; 0.1 ppt
	Accuracy	$\pm 1\%$ of reading ($\pm 0.01 \text{ ppm}$)
	Factor	0.40 to 1.00
Resistivity	Range	1.0 to 99.9 $\Omega \cdot \text{cm}$; 100 to 999 $\Omega \cdot \text{cm}$; 1.00 to 9.99 $\text{k}\Omega \cdot \text{cm}$; 10.0 to 99.9 $\text{k}\Omega \cdot \text{cm}$; 100 to 999 $\text{k}\Omega \cdot \text{cm}$; 1.00 to 9.99 $\text{M}\Omega \cdot \text{cm}$; 10.0 to 100.0 $\text{M}\Omega \cdot \text{cm}$
	Resolution	0.1 $\Omega \cdot \text{cm}$; 1 $\Omega \cdot \text{cm}$; 0.01 $\text{k}\Omega \cdot \text{cm}$; 0.1 $\text{k}\Omega \cdot \text{cm}$; 1 $\text{k}\Omega \cdot \text{cm}$; 0.01 $\text{M}\Omega \cdot \text{cm}$; 0.1 $\text{M}\Omega \cdot \text{cm}$
	Accuracy	$\pm 2\%$ of reading ($\pm 1 \Omega \cdot \text{cm}$)
Salinity	Range	practical salinity scale: 0.00 to 42.00 psu; natural sea water scale: 0.00 to 80.00 ppt; percent scale: 0.0 to 400.0% NaCl
	Resolution	0.01 for practical scale/natural sea water scale; 0.1% for percent scale
	Accuracy	$\pm 1\%$ of reading
	Calibration	percent scale—one-point (with HI7037 standard)
Temperature	Range	-20.0 to 120°C; -4.0 to 248.0°F; 253.15 to 393.15K
	Resolution	0.1°C; 0.1°F; 0.1K
	Accuracy	$\pm 0.2^\circ\text{C}$; $\pm 0.4^\circ\text{F}$; $\pm 0.2\text{K}$ (excluding probe error)
	Calibration	three-point
Ordering Information	HI5321-01 (115V) is supplied with HI76312 conductivity probe, HI76404N electrode holder, 12 VDC power adapter and instructions.	



HI2300 Autoranging Bench Meter

EC/TDS/Salinity and Temperature

- **Autoranging**
 - Automatically chooses the best measurement scale for high accuracy in very low or very high conductivity levels without changing probes
- Automatic (ATC), Manual (MTC) or No (NoTC) temperature compensation
- HI76310 platinum, four-ring conductivity/TDS probe with built-in temperature sensor included
- PC compatible via USB with optional HI92000 software and HI920013 USB cable
- GLP Features—Meets Good Laboratory Practices
- Log-on-demand up to 500 samples

Specifications

EC	Range	0.00 to 29.99 $\mu\text{S}/\text{cm}$; 30.0 to 299.9 $\mu\text{S}/\text{cm}$; 300 to 2999 $\mu\text{S}/\text{cm}$; 3.00 to 29.99 mS/cm ; 30.0 to 200.0 mS/cm ; up to 500.0 mS/cm (actual EC)*
	Resolution	0.01 $\mu\text{S}/\text{cm}$; 0.1 $\mu\text{S}/\text{cm}$; 1 $\mu\text{S}/\text{cm}$; 0.01 mS/cm ; 0.1 mS/cm
	Accuracy	$\pm 1\%$ of reading \pm (0.05 $\mu\text{S}/\text{cm}$ or 1 digit)
	Calibration	automatic, one-point with six memorized values (84, 1413, 5000, 12880, 80000, 111800 $\mu\text{S}/\text{cm}$)
TDS	Range	0.00 to 14.99 mg/L (ppm); 15.0 to 149.9 mg/L (ppm); 150 to 1499 mg/L (ppm); 1.50 to 14.99 g/L (ppt); 15.0 to 100.0 g/L (ppt); up to 400.0 g/L (actual TDS)*, with 0.80 conversion factor
	Resolution	0.01 mg/L ; 0.1 mg/L ; 1 mg/L ; 0.01 g/L ; 0.1 g/L
	Accuracy	$\pm 1\%$ of reading \pm (0.03 mg/L or 1 digit)
	Calibration	one-point, with HI7037 calibration solution
Salinity	Range	0.0 to 400.0% NaCl
	Resolution	0.1%
	Accuracy	$\pm 1\%$ of reading
	Calibration	one-point, with HI7037 calibration solution
Temperature	Range	-20.0 to 120.0°C
	Resolution	0.1°C
	Accuracy	$\pm 0.4^\circ\text{C}$
	Calibration	two-point, at 0 and 50°C
Ordering Information	HI2300-01 (115V) is supplied with HI76310 conductivity probe, 12 VDC adapter and instructions.	

CIP (Clean-in-Place) Systems

Before the advent of CIP (clean-in-place) systems, process equipment had to be disassembled and cleaned manually prior to resuming operations. CIP systems permit the cleaning of process equipment without disassembly, increasing the efficiency of food manufacturing processes which require strict cleaning regiments to maintain safe and consistent products. These systems offer the further benefit of being faster, more consistent and less labor-intensive than conventional cleaning practices. While there are many different configurations for a CIP system, they generally operate by using a rapidly flowing, turbulent solution of cycling cleaning chemicals at elevated temperature. Different chemical solutions are passed through the equipment in a sequence to clean different contaminants. For example, a basic solution may be used to remove organic material, and then an acidic solution may be passed through the equipment to eliminate mineral deposits. Chemicals that are commonly used in a CIP system vary based upon the process but include acids, bases and sanitizers. The concentrations of cleaning chemicals as well as the effectiveness of sanitization are essential to monitor to ensure a safe and efficient process. Just as important, the equipment has to be thoroughly rinsed of chemicals with clean water before the process can be restarted; monitoring the electrical conductivity of rinse water guarantees proper rinsing. Hanna offers a wide range of process and portable analytical instrumentation to monitor CIP systems, including pH, ORP, and electrical conductivity (EC).

EC and TDS Calibration Solutions

Proper calibration of the instrument and sensor measuring system will ensure your results are accurate and repeatable.

EC Calibration Solutions

EC Value @25°C	Code	Size	Package
12880 $\mu\text{S}/\text{cm}$	HI7030L	500 mL	bottle
1413 $\mu\text{S}/\text{cm}$	HI7031L	500 mL	bottle
84 $\mu\text{S}/\text{cm}$	HI7033L	500 mL	bottle
80000 $\mu\text{S}/\text{cm}$	HI7034L	500 mL	bottle
111800 $\mu\text{S}/\text{cm}$	HI7035L	500 mL	bottle
5000 $\mu\text{S}/\text{cm}$	HI7039L	500 mL	bottle



TDS Calibration Solutions

TDS Value @25°C	Code	Size	Package
1382 mg/L (ppm)	HI7032L	500 mL	bottle
12.41 g/L (ppt)	HI7036L	500 mL	bottle
1382 mg/L (ppm)	HI6032	500 mL	bottle, with certificate of analysis. 0.7 conversion factor





Quick to connect probe cable

HI98192 Graphic Display Portable Meter

EC/TDS/Resistivity/Salinity Meter with USP <645>

- Measures from ultra pure water to high levels of salinity
- Salinity can be displayed as natural seawater scale, practical salinity scale and percentage scale
- Log-on-demand up to 400 samples
- Backlit, graphic LCD display
- Dedicated HELP key
- GLP Features—Meets Good Laboratory Practices
- IP67 waterproof protection for field use
- BEPS (Battery Error Prevention System) and battery life indicator
- PC connectivity via USB with HI92000 software and HI920015 USB cable

The HI98192 is a waterproof, portable conductivity meter that has an expanded conductivity range from 0.000 $\mu\text{S}/\text{cm}$ to 400 mS/cm , as well as TDS, resistivity and three salinity scales. This meter automatically recognizes the probe type (two or four-ring) and allows the user to adjust the nominal cell constant. EC and TDS measurements are fully customizable and include a selectable TDS factor between 0.40 and 1.00.

Ten sets of customized measurement parameters can be stored as a user profile and recalled for later use.

Designed for field use, this instrument can be easily operated with one hand and includes a rugged carrying case. With an extended battery life of up to 200 hours, users are assured long operation.

Specifications

EC	Range	0.000 to 9.999 $\mu\text{S}/\text{cm}^*$; 10.00 to 99.99 $\mu\text{S}/\text{cm}$; 100.0 to 999.9 $\mu\text{S}/\text{cm}$; 1.000 to 9.999 mS/cm ; 10.00 to 99.99 mS/cm ; 100.0 to 400.0 mS/cm (up to 1000.0 mS/cm actual conductivity)** (autoranging)
	Resolution	0.001 $\mu\text{S}/\text{cm}^*$; 0.01 $\mu\text{S}/\text{cm}$; 0.1 $\mu\text{S}/\text{cm}$; 0.001 mS/cm ; 0.01 mS/cm ; 0.1 mS/cm
	Accuracy	$\pm 1\%$ of reading ($\pm 0.01 \mu\text{S}/\text{cm}$ or 1 digit, whichever is greater)
	Calibration	automatic up to five-points with seven memorized standards (0.00 $\mu\text{S}/\text{cm}$, 84.0 $\mu\text{S}/\text{cm}$, 1.413 mS/cm , 5.00 mS/cm , 12.88 mS/cm , 80.0 mS/cm , 111.8 mS/cm)
TDS	Range	0.00 to 99.99 mg/L (ppm); 100.0 to 999.9 mg/L (ppm); 1.000 to 9.999 g/L (ppt); 10.00 to 99.99 g/L (ppt); 100.0 to 400.0 g/L (ppt) (autoranging)
	Resolution	0.01 mg/L (ppm); 0.1 mg/L (ppm); 0.001 g/L (ppt); 0.01 g/L (ppt); 0.1 g/L (ppt)
	Accuracy	$\pm 1\%$ of reading ($\pm 0.05 \text{mg}/\text{L}$ (ppm) or 1 digit, whichever is greater)
Resistivity	Range	1.0 to 99.9 $\Omega \cdot \text{cm}$; 100 to 999 $\Omega \cdot \text{cm}$; 1.00 to 9.99 $\text{K}\Omega \cdot \text{cm}$; 10.0 to 99.9 $\text{K}\Omega \cdot \text{cm}$; 100 to 999 $\text{K}\Omega \cdot \text{cm}$; 1.00 to 9.99 $\text{M}\Omega \cdot \text{cm}$; 10.0 to 100.0 $\text{M}\Omega \cdot \text{cm}^*$ (autoranging)
	Resolution	0.1 $\Omega \cdot \text{cm}$; 1 $\Omega \cdot \text{cm}$; 0.01 $\text{K}\Omega \cdot \text{cm}$; 0.1 $\text{K}\Omega \cdot \text{cm}$; 1 $\text{K}\Omega \cdot \text{cm}$; 0.01 $\text{M}\Omega \cdot \text{cm}$; 0.1 $\text{M}\Omega \cdot \text{cm}^*$
	Accuracy	$\pm 1\%$ of reading ($\pm 10 \Omega \cdot \text{cm}$ or 1 digit, whichever is greater)
Salinity	Range	% NaCl: 0.0 to 400.0%; practical salinity: 0.00 to 42.00 (PSU); seawater scale: 0.00 to 80.00 (ppt)
	Resolution	0.1%; 0.01
	Accuracy	$\pm 0.2^\circ\text{C}$ (excluding probe error)
	Calibration	one-point only in % range (with HI7037 standard); use conductivity calibration for all other ranges
Temperature	Range	-20.0 to 120.0°C ; -4.0 to 248.0°F
	Resolution	0.1 $^\circ\text{C}$; 0.1 $^\circ\text{F}$
	Accuracy	$\pm 0.2^\circ\text{C}$; $\pm 0.4^\circ\text{F}$ (excluding probe error)
	Calibration	one or two-point

Ordering Information

HI98192 is supplied with HI763133 conductivity probe, HI7031M 1413 $\mu\text{S}/\text{cm}$ calibration solution (230 mL), HI7035M 111.8 mS/cm calibration solution (230 mL), 100 mL plastic beaker (2), HI92000 PC software, HI920015 micro USB cable, 1.5V AA batteries (4), instruction manual, quick start guide, quality certificate and rugged carrying case.

* The 0.000 $\mu\text{S}/\text{cm}$ EC range and 0.1 $\text{M}\Omega \cdot \text{cm}$ resistivity range are not available with the optional 4m cable probe
 **Uncompensated temperature reading

HI9835 EC/TDS/Salinity/°C Meter

- Waterproof
- Auto-ranging
- Automatic Temperature Compensation
- Backlit, graphic LCD display
- BEPS (Battery Error Prevention System)
- Help feature with on-screen user guides

HI9835 is a handheld conductivity/TDS/salinity/temperature meter. Users are provided with a series of diagnostic features and messages on the LCD which help guide through calibration, operation and troubleshooting.

Conductivity and TDS measurement parameters are selectable such as: cell constant range from 0.500 to 1.700, temperature coefficient from 0.00 to 6.00%/°C, temperature reference from 20 to 25°C and a selectable TDS factor of 0.40 to 0.80.

The autoranging feature of the EC and TDS modes automatically sets the meter to the scale with the highest possible resolution. The auto endpoint feature automatically freezes the display once a stable reading is reached.



HI9033 Multi-range EC Meter

- Four-ring technology
- Waterproof
- Automatic Temperature Compensation
- BEPS (Battery Error Prevention System)
- One point calibration

The HI9033 is a rugged conductivity meter designed to hold up under extended use in wet, humid and dusty conditions. This meter has the advantage of measuring samples from deionized water to brine without having to switch or recalibrate the probe.



Specifications	HI9033 (EC)
Range	0.0 to 199.9 µS/cm; 0 to 1999 µS/cm; 0.00 to 19.99 mS/cm; 0.0 to 199.9 mS/cm
Resolution	0.1 µS/cm; 1 µS/cm; 0.01 mS/cm; 0.1 mS/cm
Accuracy (@20°C/68°F)	±1% F.S. (excluding probe error)
Calibration	manual, one-point
Ordering Information	HI9033 is supplied with HI76302W conductivity probe, 9V battery, instructions and rugged carrying case.

Specifications

EC	Range	0.00 to 29.99 µS/cm; 30.0 to 299.9 µS/cm; 300 to 2999 µS/cm; 3.00 to 29.99 mS/cm; 30.0 to 200.0 mS/cm; up to 500.0 mS/cm (actual EC)*
	Resolution	0.01 µS/cm; 0.1 µS/cm; 1 µS/cm; 0.01 mS/cm; 0.1 mS/cm
	Accuracy	±1% of reading (±0.05 µS/cm or 1 digit)
	Calibration	automatic, one-point with six memorized values (84, 1413, 5000, 12880, 80000, 111800 µS/cm)
TDS	Range	0.00 to 14.99 mg/L (ppm); 15.0 to 149.9 mg/L (ppm); 150 to 1499 mg/L (ppm); 1.50 to 14.99 g/L (ppt); 15.0 to 100.0 g/L (ppt); up to 400.0 g/L (ppt) (actual TDS)* with 0.80 conversion factor
	Resolution	0.01 mg/L (ppm); 0.1 mg/L (ppm); 1 mg/L (ppm); 0.01 g/L (ppt); 0.1 g/L (ppt)
	Accuracy	±1% of reading (±0.03 mg/L (ppm) or 1 digit, whichever greater)
Salinity	Range	0.0 to 400.0% NaCl
	Resolution	0.1%
	Accuracy	±1% of reading
	Calibration	one-point with HI7037 calibration solution
Temperature	Range	-20.0 to 120.0°C
	Resolution	0.1°C
	Accuracy	±0.2°C (excluding probe error)
	Calibration	two-point, at 0 and 50°C (32 and 122°F)
Ordering Information	HI9835 is supplied with HI76309 conductivity probe, 1.5V AAA batteries, instructions and rugged carrying case.	

*Uncompensated temperature reading

HI98308 Water Purity Tester

The Pure Water Test (PWT) enables you to check distilled, demineralized or reverse osmosis water purity in laboratory or industrial environments.

Specifications

Range	0.0 to 99.9 µS/cm
Resolution	0.1 µS/cm
Accuracy	±2% F.S.
Calibration	manual, one-point
Ordering Information	HI98308 (PWT) is supplied with protective cap, calibration screwdriver, 1.5V (4) batteries and instructions.



HI98311 • HI98312

EC/TDS/Temperature Testers

- Waterproof and designed to float
- Automatic Temperature Compensation with adjustable β
- Hold button to freeze readings on display
- BEPS (Battery Error Prevention System)
- Battery % level and stability indicators
- Auto shut-off
- Adjustable TDS conversion factor from 0.45 to 1.00



- HI73311 Replaceable graphite electrode
 - An easy-to-replace graphite electrode with a sturdy, snap-in connector means there are no pins to bend or break.
 - The graphite conductivity electrode offers greater accuracy by resisting contamination by salt deposits in the sample.

Specifications	HI98311 (DiST®5)	HI98312 (DiST®6)	
EC	Range	0 to 3999 μ S/cm	0.00 to 20.00 mS/cm
	Resolution	1 μ S/cm	0.01 mS/cm
	Accuracy	$\pm 2\%$ F.S.	$\pm 2\%$ F.S.
TDS	Range	0 to 2000 mg/L (ppm)	0.00 to 10.00 g/L (ppt)
	Resolution	1 mg/L (ppm)	0.01 g/L (ppt)
	Accuracy	$\pm 2\%$ F.S.	$\pm 2\%$ F.S.
Temperature	Range	0.0 to 60.0°C / 32.0 to 140.0°F	0.0 to 60.0°C / 32.0 to 140.0°F
	Resolution	0.1°C / 0.1°F	0.1°C / 0.1°F
	Accuracy	$\pm 0.5^\circ\text{C} / \pm 1^\circ\text{F}$	$\pm 0.5^\circ\text{C} / \pm 1^\circ\text{F}$
Additional Specifications	Calibration	automatic, one-point at 1413 μ S/cm or 1382 mg/L (ppm)	automatic, one-point at 12.88 mS/cm or 6.44 g/L (ppt)
Ordering Information	HI98311 (DiST®5) and HI98312 (DiST®6) are supplied with HI73311 EC/TDS probe, HI73128 probe removal tool, 1.5V (4) batteries and instructions.		

DiST®: HI98301 • HI98302 HI98303 • HI98304 EC and TDS Testers

- Automatic temperature compensation
- One-point calibration

DiSTs are rugged and reliable pocket-sized testers that offer quick and accurate readings of conductivity or TDS.

These testers feature an amperometric graphite electrode that provides better repeatability in measurements, since they do not oxidize. An amperometric measurement of EC/TDS is based on Ohm's Law, $I = V/R$, where R depends on the distance between two pins and their surface. Oxidation changes both the distance and surface, which will affect accuracy. The DiSTs non-oxidizing graphite pins are able to provide an optimal surface for accurate, dependable results.

When calibration is needed, simply submerge the electrode tip into calibration solution and adjust the trimmer on the side of the tester.



- Exposed temperature sensor
 - These testers feature exposed temperature sensors for faster response times.
- Guides
 - The max level guide lets you know how deep to submerge the probe.

Specifications	HI98301 (DiST® 1)	HI98302 (DiST® 2)	HI98303 (DiST® 3)	HI98304 (DiST® 4)
Range	1999 mg/L (ppm)	10.00 g/L (ppt)	1999 μ S/cm	19.99 mS/cm
Resolution	1 mg/L (ppm)	0.01 g/L (ppt)	1 μ S/cm	0.01 mS/cm
Accuracy (@20°C/68°F)	$\pm 2\%$ F.S.	$\pm 2\%$ F.S.	$\pm 2\%$ F.S.	$\pm 2\%$ F.S.
TDS Factor	0.5	0.5	-	-
Calibration Solution	HI70032: 1382 ppm	HI70038: 6.44 ppt	HI70031: 1413 mS/cm	HI70039: 5.00 mS/cm HI70030: 12.88 mS/cm
Calibration	manual, one-point	manual, one-point	manual, one-point	manual, one-point
Ordering Information	HI98301 (DiST®1), HI98302 (DiST®2), HI98303 (DiST®3) and HI98304 (DiST®4) are supplied with protective cap, screwdriver, 1.5V (4) batteries and instructions.			



HI5421 Research Grade Bench Meter

Dissolved Oxygen and BOD/OUR/SOUR Modes

- Automatic, Manual and AutoHold logging modes
- Log up to 100 lots; 10,000 samples (automatic), 5,000 samples (manual)
- Up to 10 user profiles can be saved and recalled
- Thin, polarographic DO probe with internal temperature sensor included
- GLP features—Meets Good Laboratory Practices
- PC compatible via USB with HI92000 software
- Automatic barometric pressure compensation
- Salinity compensation
- Inside and outside limit alarms for DO, BOD, OUR and SOUR
- On-screen tutorials and directions
- Capacitive touch keypad

HI5421 is a research grade dissolved oxygen bench meter with extensive capabilities in measuring DO as well as BOD (Biological Oxygen Demand), OUR (Oxygen Uptake Rate), SOUR (Specific Oxygen Uptake Rate), atmospheric pressure and temperature.

DO measurements can be performed in ppm (mg/L) range or in % saturation and feature automatic or manual temperature and atmospheric pressure compensation, as well as manual salinity compensation.

Specifications

Dissolved Oxygen	Range	0.00 to 90.00 ppm; 0.0 to 600.0 % saturation
	Resolution	0.01 ppm; 0.1% saturation
	Accuracy	±1.5% of reading ±1 digit
	Calibration	automatic/user standard, one or two-point
Barometric Pressure	Range	450 to 850 mmHg; 560 to 1133 mBar
	Resolution	1 mm Hg
	Accuracy	±3 mm Hg + 1 least significant digit
Temperature	Calibration	one-point
	Range	-20.0 to 120.0°C; -4.0 to 248°F; 253.1 to 393.1 K
	Resolution	0.1°C/°F/K
	Accuracy	±0.2°C/°F/K (excluding probe error)
Ordering Information	HI5421-01 (115V) is supplied with HI76408 DO probe, HI76404N electrode holder, HI7041S electrolyte solution (30 mL), HI76407A membrane caps (2), 12 VDC adapter and instruction manual.	



Dissolved Oxygen in Fruit Juice

Understanding the concentration of dissolved oxygen in beverage production is extremely important. Increased DO content during the processing and storage of fruit juices can contribute to ascorbic acid degradation, as well as affecting color and flavor. Ascorbic acid is an essential food component and a natural antioxidant present in a variety of fruits and juices. It functions as an enzymatic electron donor and aids in iron absorption. During juice storage, ascorbic acid degradation due to DO present can occur over hours or weeks depending on such conditions as temperature, light, packaging permeability and pH. DO oxidation of ascorbic acid and other chemical species can lead to the formation of brown-colored compounds in a juice product, which is unappealing to a customer. Additionally, dissolved oxygen degradation of ascorbic acid can serve as a precursor to the formation of undesirable aldehydes, affecting aroma and flavor. Several methods can be employed to reduce the amount of dissolved oxygen present including vacuum-deaeration, gas sparging and membrane deaeration leading to an improvement in overall product quality. Dissolved oxygen measurements ensure quality and efficiency of fruit juice production.

HI3810 Dissolved Oxygen Test Kit

The Hanna dissolved oxygen portable test kit can determine the oxygen concentration in water quickly and easily.



Specifications

Method	titration
Range	0.0-10.0 mg/L (ppm)
Smallest Increment	0.1 mg/L (ppm)
Chemical Method	modified Winkler
# Tests	110 avg.
Ordering Information	HI3810 test kit comes with 30 mL manganous sulfate solution, 30 mL alkali-azide reagent, 60 mL sulfuric acid solution (2), 10 mL starch indicator, 120 mL titrant solution, glass bottle with stopper, 10 mL calibrated vessel and calibrated syringe with tip.



HI2400 Dissolved Oxygen Meter

Dissolved Oxygen and Temperature

- Automatic temperature compensation
- Two-point calibration
- GLP features—Meets Good Laboratory Practices
- PC compatible via USB with HI92000 software and HI920013 USB cable
- Datalogging and storage up to 8000 samples
- Manual altitude and salinity compensation

HI2400 is a dissolved oxygen benchtop meter with automatic calibration and % or mg/L (ppm) measurement range. The measurement is automatically compensated for altitude and salinity based on the user settings for altitude up to 4000 m and salinity up to 40 g/L.

Measurements are automatically temperature compensated by using the polarographic DO probe with built-in temperature sensor. This probe features screw cap membranes for easy replacement.

Specifications

Dissolved Oxygen	Range	0.00 to 45.00 mg/L (ppm); 0.0 to 300.0 % saturation
	Resolution	0.01 mg/L (ppm); 0.1 % saturation
	Accuracy (@20°C/68°F)	±1.5% F.S.
	Calibration	one or two-point at 0% (HI7040 solution) and 100% (in air)
Temperature	Range	0.0 to 50.0°C
	Resolution	0.1°C
	Accuracy (@20°C/68°F)	±0.2°C (excluding probe error)
Ordering Information	HI2400-01 (115V) are supplied with HI76407/2 dissolved oxygen probe, HI76407A membrane caps (2), HI7041S electrolyte solution (30 mL), 12 VDC adapter and instructions.	

HI98193 Dissolved Oxygen and BOD Meter

- Log-on-demand up to 400 samples
- Barometric, salinity and temperature compensation
- Backlit, graphic LCD display
- Dedicated HELP key
- GLP Features—Meets Good Laboratory Practices
- IP67 waterproof protection for field use
- BEPS (Battery Error Prevention System)
- Battery life indicator
- PC connectivity via USB with HI92000 software and HI920015 USB cable



The HI98193 portable dissolved oxygen and BOD meter has extended ranges of up to 50 mg/L (ppm) and 600% saturation. In measuring dissolved oxygen, compensations for salinity, temperature and pressure are essential to improve the precision of your readings. Salinity compensation allows for direct determination of DO in saline waters. Temperature compensation is automatic with the built-in sensor, which features a one- or two-point temperature calibration. Pressure compensation with the meter's built-in barometer can be validated with automatic or manual measurement and calibration with user-selectable units (mmHg, inHg, atm, psi, kPa, mbar). With the internal barometer, the instrument is able to compensate for changes in barometric pressure so there is no need for charts, altitude information or external barometric pressure information.

An out of calibration range warning can be activated to alert the user in the event that a reading is taken too far from the calibration's periphery.

Specifications

Dissolved Oxygen	Range	0.00 to 50.00 mg/L (ppm); 0.0 to 600.0 % saturation
	Resolution	0.01 mg/L (ppm); 0.1% saturation
	Accuracy (@20°C/68°F)	±1.5% of reading ±1 digit
Calibration	automatic one or two point at 100 % (8.26 mg/L) and 0 % (0 mg/L); manual one point using a value entered by the user in % saturation or mg/L	
	Barometric Pressure	
Barometric Pressure	Range	450 to 850 mmHg
	Resolution	1 mm Hg
	Accuracy (@20°C/68°F)	± 3 mmHg within ±15% from the calibration point
Calibration	one-point at any in range pressure value	
Temperature	Range	-20.0 to 120.0°C; -4.0 to 248.0°F
	Resolution	0.1°C; 0.1°F
	Accuracy (@20°C/68°F)	±0.2°C; ±0.4°F (excluding probe error)
Calibration	one or two-point at any in range temperature value	
Ordering Information	HI98193 is supplied with HI76407/3 DO probe with protective sleeve, membrane caps (2), HI 7040 bi-component zero oxygen solution (230 mL), HI7041S electrolyte solution (30 mL), 100 mL plastic beaker (2), HI92000 PC software, HI920015 micro USB cable, 1.5V AA batteries (4), instruction manual, quick start guide, quality certificate and rugged carrying case.	

★ Application Highlight

HI98193 and Dissolved Oxygen

An orange juice producer was interested in monitoring a variety of parameters including pH, temperature, and dissolved oxygen of their finished juice products. They were particularly concerned with the dissolved oxygen concentration values with respect to product packaging material; they considered that the permeability of their juice container could affect the dissolved oxygen concentration over time. The customer was looking to relate the shelf life of their juice product to the dissolved oxygen concentration during refrigeration, storage and temperature variations associated with the shipping and distribution cycle. Their initial experiments would monitor juice product in various packaging materials over different temperature ranges for a period of several weeks; their final experiments would monitor juice product as it moved through shipping and distribution. The customer was ultimately looking for a portable and reliable device for measuring dissolved oxygen in their juice containers.

Hanna recommended the waterproof, portable HI98193 Dissolved Oxygen Meter. The customer wished to maintain low head-space in their containers to reduce exposure to the sample when opening the container for analysis. For this concern, Hanna provided the HI76407/4 Polarographic Dissolved Oxygen Probe, without the protective sleeve. The HI76407/4 is the same as the HI76407/4F probe but without threads for the protective sleeve. The HI76407/4 tapered design allows for a form fit between the probe and the container, minimizing the amount of air entering into the sample during analysis. The customer appreciated that the local office was able to accommodate their specific needs by changing the HI76407/4F probe for the HI76407/4 version. All readings taken were automatically compensated for barometric pressure and temperature. The customer liked the log-on-demand function, allowing them to record up to 400 dissolved oxygen samples and aiding in the speed of the overall data recording. The customer also liked that the data could be transferred from the meter to a PC using the HI920015 USB cable and HI92000 software. Overall, the customer felt that the HI98193 met all of their needs, and appreciated that the meter was supplied with all the accessories including spare membranes, fill solution and a hard shell carrying case.



HI9146 Dissolved Oxygen Meter

- BEPS (Battery Error Prevention System)
- Two-point calibration
- GLP features—Meets Good Laboratory Practices
- Backlit LCD with on-screen tutorial messages
- Temperature, altitude and salinity compensation

HI9146 is a water-resistant dissolved oxygen meter that measures up to 300% saturation or 45 ppm (mg/L) with temperature compensation and automatic calibration.

HI76407A/P Easy, Screw Cap DO Membranes



When the PTFE (PolyTetraFluoro-Ethylene) membrane of the protective cap wears, it is always good to have a back-up.

HI76407A/P contains 5 ready-to-use, replacement membranes.

HI7040 • HI7041 DO Solutions



It is crucial to the performance of your DO probe, to keep the sensor active with regular maintenance.

- HI7040L** zero oxygen, 500 mL
- HI7041S** refilling electrolyte (30 mL)
- HI7041M** refilling electrolyte (230 mL)
- HI7041L** refilling electrolyte (500 mL)

Specifications

Dissolved Oxygen	Range	0.00 to 45.00 mg/L (ppm); 0.0 to 300.0% saturation
	Resolution	0.01 mg/L (ppm); 0.1% saturation
	Accuracy (@ 20°C/68°F)	±1.5% F.S.
Temperature	Range	0.0 to 50.0°C
	Resolution	0.1°C
	Accuracy (@ 20°C/68°F)	±0.2°C (excluding probe error)
Additional Specifications	DO Calibration	one or two-point at 0% (HI7040 solution) and 100% (in air)

Ordering Information

HI9146-04 is supplied complete with HI76407/4F probe with 4 m (13.1') cable, HI76407A membranes (2), HI7041S electrolyte solution (30 mL), 1.5V AAA batteries, instructions and rugged carrying case.
HI9146-10 is supplied complete with HI76407/10F probe with 10 m (32.8') cable, HI76407A membranes (2), HI7041S electrolyte solution (30 mL), 1.5V AAA batteries, instructions and rugged carrying case.



HI96785 Honey Color Portable Analyzer

- Removes subjectivity
- CAL Check™
- BEPS (Battery Error Prevention System)
- GLP features

The HI96785 portable microprocessor analyzer measures the percent light transmittance of honey compared to analytical reagent grade glycerol. The transmittance value allows identification of the honey Pfund grade. The instrument directly displays the measurement result expressed in mm Pfund.

Measurements are made using matched square optical cuvettes having a 10 mm light path.

Specifications

Range	0 to 150 mm Pfund
Resolution	1 mm Pfund
Accuracy @ 25°C (77°F)	±2 mm Pfund @ 80mm Pfund
Method	direct measure

Ordering Information

HI96785 is supplied with sample cuvettes (5), 9V battery, light shield cap, cloth for cuvette wiping, rigid carrying case, instrument quality certificate and instruction manual.

Accessories

HI93703-56	consists of 82 matched square disposable cuvettes, 30 mL of glycerol and (2) 5 mL syringes (75 tests average)
HI70662	cleaning solution for honey portable analyzer (30 mL)

HI96785 for Honey Color Analysis

A research scientist was comparing the physiochemical and antioxidant properties of honey and needed an accurate way to report honey color. For his research, four different types of honey were compared; these included gelam, longan, rubber tree and sourwood honeys, all of which are named based on the plant which the nectar was collected from. These varieties of honey are commonly introduced to food products, as well as used in traditional medicines. Mānuka honey originates from New Zealand, and was chosen as the standard in the study because of its benefits and medicinal properties, specifically its antibacterial and antioxidant characteristics. By comparing the four honey types to Mānuka honey, the researcher hoped to determine antioxidant activity, ultimately promoting bee keeping and increasing the value of honey in the local market.

The research scientist looked at many different honey characteristics including pH, EC/ TDS and color. He was already using Hanna products for pH and EC/TDS to provide measurements for regulatory purposes, but for the purpose of this study he wished to establish a relationship between physical parameters and honey antioxidants. The method he was using involved a visual comparison of the honey sample to a set of standards; he concluded through inconsistent results that this method was too subjective and inaccurate. The researcher contacted Hanna about the HI96785 Honey Color Portable Photometer, which gives results in mm Pfund. The Pfund scale, ranging from 0 to 140 mm Pfund, was established by the US Department of Agriculture (USDA) as a color classification for extracted honey. The color scale includes the classifications water white, extra white, white, extra light amber, light amber, amber and dark; as the color of honey gets darker, the Pfund value increases, signifying a higher quality of honey. The researcher appreciated that the HI96785 came with a table that easily allowed him to determine the color classification based on the Pfund value. He also liked that the HI96785 was so easy to use and gave a direct measurement, which took away the subjectivity of comparing the samples to a set of standards. The HI96785 comes with a glycerol standard, but additional standards and cuvettes can be ordered for additional analysis. The HI93703-56 Kit includes 82 cuvettes, 30 mL of glycerol and two 5 mL syringes. The glycerol standard is used to calibrate the instrument before analysis, after which the honey sample is placed into a disposable cuvette, inserted into the instrument and covered with the light shield for analysis.

The Color of Honey

The natural color of honey presents many tonalities: from straw yellow to amber, from dark amber to almost black with a hint of red. The color of untreated honey originates from the botanical varieties used by the bees: for this reason, its coloration allows one to commercially identify the original floral type.

The color of honey tends to darken with age or change according to the method of conservation or production used by beekeepers, e.g., the use of old beehives, contact with metals, the temperature of conservation, exposure to light, etc. The classes of color are expressed in millimeters (mm) on the Pfund scale, compared to an analytical standard scale of reference on the graduation of glycerin.

USDA Color Standards Designations Color Range Pfund Scales (mm)

Water White	8 or less
Extra White	Over 8 to and including 17
White	Over 17 to and including 34
Extra Light Amber	Over 34 to and including 50
Light Amber	Over 50 to and including 85
Amber	Over 85 to and including 114
Dark Amber	Over 114

★ Application Highlight

HI96735 & CIP

A dairy processing plant contacted Hanna Instruments with the intent to monitor the hardness of water in their CIP system. The plant needed to periodically measure their water hardness to assess the efficiency of their cleaning process and to determine if water softening was necessary. Hanna provided the customer with the HI96735 Portable Photometer for Total Hardness. The HI96735 is equipped to measure low, medium and high range concentrations, so the customer was able to accurately measure their water both before and after softening. The timer feature was greatly appreciated, as it allowed the user to take accurate measurements by keeping the reaction time constant across measurements. They also felt confident with this meter because of the consistency provided by the positive-locking feature, which ensures the cuvette is positioned the same for each measurement. The calibration of the HI96735 using the two supplied cuvettes of CAL Check™ Standards was straightforward for the customer, and they appreciated how easily the meter could be carried throughout their processing plant for spot checks. Overall, the customer was happy with the HI96735 for providing a simple, yet effective method for determining the hardness of their feed water.

Application Note

Water Hardness & CIP Systems

Foodborne illness is one of the most common public health issues in the United States, with approximately 76 million food-related illnesses occurring each year. In an effort to minimize foodborne illness, the United States Public Health Service (USPHS) closely inspects and regulates the country's food production. As a result, cleanliness is among the primary directives of any food processing plant to ensure compliance with the USPHS. Large food processing plants utilize clean-in-place (CIP) systems, which permit the cleaning of process machinery without having to completely disassemble the equipment. Unlike conventional cleaning systems where production must be halted for disassembly, cleaning and reassembly, CIP systems allow production processes to run continuously. An additional benefit to CIP systems is lower production costs, as there is no need for manual intervention. However, since there is minimal human involvement, both water and chemicals used for the CIP process must be monitored to ensure that they are suitable for cleaning purposes.

Water hardness is caused by dissolved salt ions, predominantly calcium and magnesium. Hardness in water poses a significant issue in CIP systems, as it can interfere with the effectiveness of sanitizers and caustic detergents. Water hardness also contributes to scale buildup in both the CIP equipment and process equipment. Scaling greatly reduces cleaning efficiency and consequently increases the costs of operation. As a result, the selection and concentration of chemicals used to treat cleaning water must be determined based on the extent of hardness. In circumstances where hardness exceeds 100 mg/L, the concentration of chemicals in cleaning solutions must be increased. However, if hardness exceeds 500 mg/L, water must be treated with a softener such as phosphate or EDTA. These softeners are added to detergents, and function by chelating the main constituents of hardness: calcium and magnesium. By removing calcium and magnesium from the water, detergents and sanitizers can work effectively. Optimal, efficient CIP systems ultimately require monitoring the hardness of the source water.

HI96735 Hardness, EPA Portable Photometer



- CAL Check™
- BEPS (Battery Error Prevention System)
- GLP Features

Specifications

	Hardness LR (P1)	Hardness MR (P2)	Hardness HR (P3)
Range	0 to 250 mg/L (ppm)	200 to 500 mg/L (ppm)	400 to 750 mg/L (ppm)
Resolution	1 mg/L from 0 to 100 mg/L, 5 mg/L from 100 to 250 mg/L	1 mg/L from 0-100 5 mg/L from 100-750	5 mg/L
Accuracy @ 25°C (77°F)	±5 mg/L ±4% of reading	±7 mg/L ±3% of reading	±10 mg/L ±2% of reading
Method	adaptation of the EPA recommended method 130.1		

Ordering Information

HI96735 is supplied with sample cuvettes (2) with caps, 9V battery, instrument quality certificate and instruction manual. CAL CHECK™ standards and testing reagents sold separately

Reagents and Standards

HI96735-11	CAL CHECK™ standard cuvettes
HI93735-00	reagents for 100 tests (0-250 mg/L)
HI93735-01	reagents for 100 tests (200-500 mg/L)
HI93735-02	reagents for 100 tests (400-750 mg/L)
HI93735-0	reagents for 100 tests (0-750 mg/L)

The reagents are in liquid and powder form and are supplied in bottles and in packets. The amount of reagent is precisely dosed to ensure maximum repeatability.

Hardness (as CaCO₃) Test Kits

HI3812 Hardness

HI3841 Hardness, Medium Range

HI38033 Total Hardness (gpg*)



Specifications	HI3812 Hardness	HI3841 Hardness, MR	HI38033 Total Hardness
Method	titration	titration	titration
Range*	0.0-30.0 mg/L (ppm) 0-300 mg/L (ppm)	40-500 mg/L (ppm)	0-30 gpg (0-510 mg/L)
Smallest Increment	0.3 mg/L (ppm) 3 mg/L (ppm)	20 mg/L (ppm)	1 gpg
Chemical Method	EDTA	EDTA	EDTA
# Tests	100	50 avg.	100

Ordering Information

HI3812 test kit comes with 30 mL hardness buffer, 10 mL calmagite indicator, 120 mL EDTA solution, 20 mL plastic beaker with cap, 50 mL plastic beaker with cap and 1 mL syringe with tip

HI3841 test kit comes with 30 mL hardness MR reagent and 50 mL calibrated vessel.

HI38033 test kit comes with 30 mL buffer solution, 10 mL calmagite indicator, 75 mL EDTA solution (2), 20 mL plastic beaker with cap and 1 mL plastic pipette.

*Expressed as grains per gallon

HI9564 Thermohygrometer

with Calibration Data-Logging Probe

- Hold feature freezes reading on the display
- BEPS (Battery Error Prevention System)
- Backlit LCD

The HI9564 is a portable thermohygrometer designed to provide peak performance in harsh environments.

The HI70602 RH probe with built-in temperature sensor features an internal microchip that can store calibration data. When the probe is connected to another hygrometer, the microchip transfers the stored calibration data and eliminates the need to recalibrate the instrument.



Specifications

RH	Range	20.0 to 95.0%
	Resolution	0.1% RH
	Accuracy	±3% RH (50 to 85% RH and 15 to 40°C); ±5% RH (outside)
Temperature	Range	0.0 to 60.0°C / 32 to 140.0°F*
	Resolution	0.1°C / 0.1°F
	Accuracy	±0.5°C / ±1°F
Ordering Information	HI9564 is supplied with HI70602 relative humidity probe, 9V battery and instructions.	

Parameter Highlight

Humidity

Monitoring humidity levels is a common practice in the food industry, from shipping different items to properly drying pasta for consumption. In food storage, maintaining the ideal humidity of 15% can be difficult as external temperatures vary. Being able to monitor humidity through a controller and make adjustments when needed greatly increases the effectiveness of storage rooms and shipping trucks. A lower humidity environment is desired for foods that release ethylene gas as they rot, which includes avocados and kiwis. However, leafy greens like spinach, basil and other herbs are kept in higher humidity environments, as the higher moisture in the atmosphere helps to keep leaves crisp. Storing food at the proper humidity levels not only prolongs the shelf life but also prevents against foodborne illness. As temperature and humidity increase, the risk of bacteria multiplying increases. This creates a hazardous environment for the food, as well as the people exposed.

Hanna offers humidity meters to help monitor this parameter. Hanna hygrometers are calibrated at the factory using three different points in a calibration chamber. To provide continued accuracy, all Hanna service centers are equipped with calibration chambers.

HI93640 Compact Thermohygrometer

with Built-in Sensor

- BEPS (Battery Error Prevention System)
- Low battery indicator

HI93640 is a compact, portable and versatile thermohygrometer that monitors relative humidity, anywhere.

The built-in thin-film capacitance sensor assures accurate humidity measurements from 10 to 95% RH with a resolution of 0.1%.

A sintered cap can be placed on the sensor shaft for protection in dusty environments. If faster response is desired, the cap can be removed.



Specifications

RH	Range	10.0 to 95.0% RH
	Resolution	0.1%
	Accuracy	±3% RH (50 to 85% RH); ±4% RH (outside)
Temperature	Range	0.1%
	Resolution	0.1°C / 0.1°F
	Accuracy	±0.5°C / ±1°F
Ordering Information	HI93640 is supplied with built in RH sensor, protective sintered cap for RH sensor, 1.5V AA battery and instructions.	

HI98601 HYGROCHECK® Relative Humidity Tester

- Pocket-sized and weighs just 2.2 oz.
- Durable housing
- Performs all relative conversions

The HYGROCHECK® uses an advanced TFPC* sensing method to measure humidity and an integrated electronic circuit to perform all relative conversions.

(*Thin Film Polymer Capacitance)

Specifications

RH	Range	10.0 to 90.0% RH
	Resolution	0.1% RH
	Accuracy	±3% F.S.
Ordering Information	HI98601 (HYGROCHECK®) is supplied complete with batteries, soft carrying case and instruction manual.	





HI3844 Hydrogen Peroxide Test Kit

Specifications

Method	titration
Range	0.00-2.00 mg/L; 0.0-10.0 mg/L
Smallest Increment	0.25 mg/L (ppm); 1.0 mg/L (ppm)
Chemical Method	iodometric
# Tests	100 avg.
Ordering Information	HI3844 test kit comes with 100 mL hydrogen peroxide reagent A, 17 g hydrogen peroxide reagent B, 30 mL hydrogen peroxide reagent C, 25 mL hydrogen peroxide reagent D, graduated plastic test tube with cap, 50 mL calibrated plastic vessel, 3 mL plastic pipette, 1 mL plastic pipette and plastic spoon.



HI3843 Hypochlorite (Bleach) Test Kit

Specifications

Method	titration
Range	50-150 g/L (ppt)
Smallest Increment	5 g/L (ppt) (0.5%)
Chemical Method	iodometric
# Tests	100 avg.
Ordering Information	HI3843 test kit comes with 30 mL potassium iodide solution, 100 packets bleach reagent B, 60 mL bleach reagent C (2), 125 mL glass Erlenmeyer flask and 1 mL plastic pipettes (25).

HI4111 Iodide Ion Selective Electrode

For use with compatible ISE meters

- See a complete list of ISE Solutions on p. 39

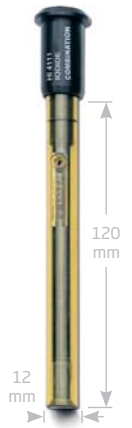

Specifications

Type	solid-state; combination
Measurement Range	1M to 1X10 ⁻⁷ M 127000 to 0.01 mg/L (ppm)
Optimum pH Range	2 to 13
Temperature Range	0 to 80°C
Approximate Slope	-56
Body O.D.	12 mm
Insertion Length	120 mm
Body Material	PEI
Cable	1 m coaxial
Connection	BNC
Ordering Information	HI4111 solid-state; half cell ISE with 1m coaxial cable and BNC connection

HI96718 Iodine Portable Photometer

- CAL Check™
- BEPS (Battery Error Prevention System)
- GLP Features



The HI96718 measures the iodine content in water samples in the 0.0 to 12.5 mg/L (ppm) range. The method is an adaptation of the Standard Methods for the Examination of Water and Wastewater, 18th edition, DPD method.

Specifications

Range	0.0 to 12.5 mg/L (ppm)						
Resolution	0.1 mg/L (ppm)						
Accuracy @ 25°C (77°F)	±0.1 mg/L ±5% of reading						
Method	adaptation of the Standard Methods for the Examination of Water and Wastewater, 18th edition, DPD method						
Ordering Information	HI96718 is supplied with sample cuvettes (2) with caps, 9V battery, instrument quality certificate and instruction manual. CAL CHECK™ standards and testing reagents sold separately						
Reagents and Standards	<table border="0"> <tr> <td>HI96718-11</td> <td>CAL Check™ standard cuvettes</td> </tr> <tr> <td>HI93718-01</td> <td>reagents for 100 tests</td> </tr> <tr> <td>HI93718-03</td> <td>reagents for 300 tests</td> </tr> </table>	HI96718-11	CAL Check™ standard cuvettes	HI93718-01	reagents for 100 tests	HI93718-03	reagents for 300 tests
HI96718-11	CAL Check™ standard cuvettes						
HI93718-01	reagents for 100 tests						
HI93718-03	reagents for 300 tests						

HI3832 • HI3879 Iodine (as I₂) Test Kits



Specifications

	HI3832	HI3879
Method	colorimetric	colorimetric
Range	0.0 to 2.5 mg/L (ppm)	0 to 5 mg/L (ppm)
Smallest Increment	0.5 mg/L (ppm)	1 mg/L (ppm)
Chemical Method	DPD	DPD
# Tests	50 avg.	100 avg.
Ordering Information	HI3832 test kit comes with 30 mL potassium iodide solution, 100 packets of bleach reagent B, 60 mL bleach reagent C (2), 125 mL glass Erlenmeyer flask and 1 mL plastic pipettes (25). HI3879 test kit comes with 100 packets of iodine reagent, color comparison cube and 2 mL plastic pipette.	



HI96759 Maple Syrup Portable Photometer

- Ideal for new Vermont (IMSI) standards
- USDA compliant

The HI96759 handheld maple syrup transmittance analyzer is a high precision, USDA compliant photometer that brings judging "by eye" to an end.

The HI96759 measures the percent light transmittance of maple syrup as compared to analytical reagent glycerol. The transmittance value allows identification of syrup quality class.

A very light syrup color is the indicator of high grade. The difference in the transmittance of light of very light syrup and a glycerol standard will be negligible. A dark-colored syrup is graded lower than a light-colored syrup. The dark-colored syrup will allow less light to pass through the cuvette as compared to glycerol standard.



 Application Note

Maple Syrup Quality

When selecting a maple syrup, it is important to consider its clarity along with color and taste. A light, clear syrup has a high level of quality, indicative of a very pure product, whereas a dark, cloudy syrup is less desirable, owing to the presence of impurities and suspended solids. In Canada and the United States, maple syrup is classified into different standards based on color and clarity. Lighter, clearer syrups are produced earlier in the season, while, darker syrups are produced later in the season. The lightest grade, produced earliest in the season and characterized by its very pale color, has a light transmittance of over 75%. The darkest grade, produced latest in the season, has a light transmittance of less than 25% (27%, non-IMSI standards).

The grade of maple syrup can be determined by using color comparators or by measuring how much light is transmitted through the syrup. Hanna provides the HI96759 handheld maple syrup transmittance analyzer, which compares the percentage of light that passes through the sample to that of a glycerol reagent. With its advanced optical system, the highly precise meter eliminates subjectivity to provide readings that are accurate and repeatable.

Range (% Transmittance)	United States, USDA	Range (% Transmittance)	State of Vermont Grades and Standards (New IMSI* standards)
75.0 to 100.0	grade A light amber	75.0 to 100.0	grade A golden color/delicate taste
60.5 to 74.9	grade A medium amber	50 to 74.9	grade A amber color/rich taste
44.0 to 60.4	grade A dark amber	25 to 49.9	grade A dark color/robust taste
27 to 43.9	grade B (extra dark)		grade A very dark color/strong taste
Less than 27	commercial	less than 25	

Specifications HI96759

Range	0.0 to 100.0% transmittance
Resolution	0.1% transmittance
Accuracy @ 25°C (77°F)	±3% @ 75.0% transmittance
Method	direct measure

Ordering Information

HI96759 are supplied with square sample cuvettes (6), light shield cap, 5 mL syringes (2), 30 mL bottle of glycerol, cuvette cleaning cloth, 9V battery, instrument quality certificate, CAL Check™ standard cuvettes, instruction manual and rigid carrying case.

Solutions and Accessories

HI93703-50	cuvette cleaning solution, 230 mL
HI93703-56	consists of 82 matched square cuvettes, glycerol standard(30 mL) and 5 mL syringes (2) (75 tests average)

*International Maple Syrup Institute



HI5521 • HI5522 Research Grade Meters

pH/ORP/ISE and EC/TDS/Resistivity/Salinity and Temperature

- CAL Check™ and calibration reminder
- Five-point pH and ISE calibration
- Automatic or manual temperature compensation
- GLP features—Meets Good Laboratory Practices
- 100 lot logging with 10,000 records/lot
- On-screen tutorials and directions
- Up to 10 user profiles can be saved and recalled
- Automatic, log-on-demand and AutoHold logging
- PC compatible via USB with HI92000 software
- Capacitive touch keypad
- Dual channels
 - The two measurement channels of the HI5522 and HI5521 are galvanically isolated to eliminate noise and instability.
- ISE mode (HI5522) equipped with four incremental methods
- One channel for pH/ORP/(ISE, HI5522) and one channel for EC/TDS/Resistivity
- Displays up to two channels at the same time
- Hold feature to freeze readings on the display



HI5521 and HI5522 are research grade benchtop instruments that feature 8 measurement parameters: pH, ORP (Oxidation Reduction Potential), ISE (HI5522 only), conductivity, resistivity, TDS, salinity and temperature.

CAL Check™

Hanna's CAL Check™ ensures accurate readings every time by alerting users of potential problems during the calibration process. The CAL Check™ system eliminates erroneous readings due to dirty or faulty pH electrodes or contaminated pH buffer solutions. After the guided calibration process, electrode condition is evaluated and an indicator is displayed informing the user of the overall pH electrode status.

Specifications	HI5521 / HI5522	
pH	Range	-2.000 to 20.000 pH
	Resolution	0.1 pH; 0.01 pH; 0.001 pH
	Accuracy	±0.1 pH; ±0.01 pH; ±0.002 pH ±1 LSD
	Calibration	automatic, up to five-point calibration, eight standard buffers available, and five custom buffers
mV	Range	±2000 mV
	Resolution	0.1 mV
	Accuracy	±0.2 mV ±1 LSD
ISE (HI5522 only)	Range	1 x 10 ⁻⁶ to 9.99 x 10 ¹⁰ concentration
	Resolution	1; 0.1; 0.01; 0.001 concentration
	Accuracy	±0.5% (monovalent ions); ±1% (divalent ions)
	Calibration	automatic, up to five-point calibration, five fixed standard solutions available for each measurement unit, and five user defined standards
Temperature	Range	-20.0 to 120.0°C; -4.0 to 248.0°F; 253.15 to 393.15K
	Resolution	0.1°C; 0.1°F; 0.1K
	Accuracy	±0.2°C; ±0.4°F; ±0.2K (without probe)
Conductivity	Range	0.000 to 9.999 µS/cm; 10.00 to 99.99 µS/cm; 100.0 to 999.9 µS/cm; 1.000 to 9.999 mS/cm; 10.00 to 99.99 mS/cm; 100.0 to 1000.0 mS/cm
	Resolution	0.001 µS/cm; 0.01 µS/cm; 0.1 µS/cm; 0.001 mS/cm; 0.01 mS/cm; 0.1 mS/cm
	Accuracy	±1% of reading (±0.01 µS/cm)
	Calibration Type	automatic standard recognition, user standard one-point / multi point calibration
TDS	Range	0.000 to 9.999 ppm; 10.00 to 99.99 ppm; 100.0 to 999.9 ppm; 1.000 to 9.999 ppt; 10.00 to 99.99 ppt; 100.0 to 400.0 ppt actual TDS (with 1.00 factor)
	Resolution	0.001 ppm; 0.01 ppm; 0.1 ppm; 0.001 ppt; 0.01 ppt; 0.1 ppt
	Accuracy	±1% of reading (±0.01 ppm)
Resistivity	Range	1.0 to 99.9 Ω•cm; 100 to 999 Ω•cm; 1.00 to 9.99 kΩ•cm; 10.0 to 99.9 kΩ•cm; 100 to 999 kΩ•cm; 1.00 to 9.99 MΩ•cm; 10.0 to 100.0 MΩ•cm
	Resolution	0.1 Ω•cm; 1 Ω•cm; 0.01 kΩ•cm; 0.1 kΩ•cm; 1 kΩ•cm; 0.01 MΩ•cm; 0.1 MΩ•cm
	Accuracy	±2% of reading (±1 Ohm x cm)
	Calibration	none
Salinity	Range	practical scale: 0.00 to 42.00 psu; natural sea water scale: 0.00 to 80.00 ppt; percent scale: 0.0 to 400.0%
	Resolution	0.01 for practical scale/natural sea water scale; 0.1% for percent scale
	Accuracy	±1% of reading
	Calibration	percent scale—one-point (with HI7037 standard)
Ordering Information	HI5521-01 (115V) and HI5522-01 (115V) are supplied with HI76312 conductivity/TDS probe, HI1131B pH electrode, HI7662-T temperature probe, HI70004 pH 4.01 buffer solution sachet, HI70007 pH 7.01 buffer solution sachet, HI700661 electrode cleaning solution sachet (2), HI7071S electrolyte solution (30 mL), HI76404N electrode holder, 12 VDC adapter and instructions.	



HI3512 Multiparameter Meter

pH/ORP/ISE and EC/TDS/Resistivity/Salinity and Temperature

- CAL Check™
- Up to five-point pH calibration
- Up to two-point EC calibration
- Automatic or manual temperature compensation
- Automatic logging up to 600 records and log-on-demand up to 400 samples
- PC connectivity via opto-isolated USB with HI92000 software
- GLP Features—Meets Good Laboratory Practices
- Outside calibration warnings and calibration due reminders
- Hold feature freezes the first stable reading on the LCD

The HI3512 is a dual-channel benchtop meter with a graphic LCD designed to provide accurate laboratory results. Channel one features pH/ORP/ISE and temperature measurement capability while channel two measures EC/TDS/salinity/resistivity and temperature.

CAL Check™

Hanna's exclusive CAL Check™ diagnostics system ensures accurate pH readings every time by alerting users of potential problems during the calibration process. The CAL Check™ system eliminates erroneous readings due to dirty or faulty pH electrodes or contaminated pH buffer solutions during calibration. After the guided calibration process, the probe condition is evaluated and an indicator is displayed informing the user of the overall pH electrode status.

Specifications

pH	Range	-2.0 to 20.0; -2.00 to 20.00; -2.000 to 20.000 pH
	Resolution	0.1 pH; 0.01 pH; 0.001 pH
	Accuracy	±0.01 pH; ±0.002 pH
	Calibration	up to five point calibration, seven standard buffers available (1.68, 4.01, 6.86, 7.01, 9.18, 10.01, 12.45), and two custom buffers
mV	Range	±2000.0 mV
	Resolution	0.1 mV
	Accuracy	±0.2 mV
ISE	Range	1.00 E ⁻⁷ to 9.99 E ¹⁰ conc.
	Resolution	3 digits 0.01, 0.1, 1, 10 conc.
	Accuracy	±0.5% of reading (monovalent ions); ±1% of reading (divalent ions)
EC	Range	0 µS/cm to 400 mS/cm (shows values up to 1000 mS/cm actual conductivity); 0.001 to 9.999 µS/cm; 10.00 to 99.99 µS/cm; 100.0 to 999.9 µS/cm; 1.000 to 9.999 mS/cm; 10.00 to 99.99 mS/cm; 100.0 to 999.9 mS/cm; 1000 mS/cm (autoranging)
	Resolution	0.001 µS/cm; 0.01 µS/cm; 0.1 µS/cm; 0.001 mS/cm; 0.01 mS/cm; 0.1 mS/cm; 1 mS/cm
	Accuracy	±1% of reading (±0.01 µS/cm or 1 digit whichever is greater) excluding probe error
TDS	Range	0.000 to 9.999 ppm; 10.00 to 99.99 ppm; 100.0 to 999.9 ppm; 1.000 to 9.999 g/L; 10.00 to 99.99 g/L; 100.0 to 400.0 g/L (autoranging)
	Resolution	0.001 ppm; 0.01 ppm; 0.1 ppm; 0.001 g/L; 0.01 g/L; 0.1 g/L
	Accuracy	±1% of reading (±0.05 ppm or 1 digit whichever greater) excluding probe error
Resistivity	Range	1.0 to 99.9 Ω•cm; 100 to 999 KΩ•cm; 1.00 to 9.99 KΩ•cm; 10.0 to 99.9 KΩ•cm; 100 to 999 KΩ•cm; 1.00 to 9.99 MΩ•cm; 10.0 to 100.0 MΩ•cm (autoranging)
	Resolution	0.1 Ω•cm; 1 Ω•cm; 0.01 KΩ•cm; 0.1 KΩ•cm; 1 KΩ•cm; 0.01 MΩ•cm; 0.1 MΩ•cm
	Accuracy	±1% of reading (±10 Ω•cm or 1 digit whichever greater) excluding probe error
Salinity	Range	% NaCl: 0.0 to 400.0 %
	Resolution	0.1%
	Accuracy	±1% of reading excluding probe error
	Calibration	max. one-point only (with HI7037 standard)
Temperature	Range	-20.0 to 120.0°C (4.0 to 248.0°F)
	Resolution	0.1°C (0.1°F)
	Accuracy	±0.2°C (±0.4°F) (excluding probe error)
Ordering Information	HI3512-01 (115V) is supplied with HI76310 conductivity/TDS probe, HI1131B pH electrode, HI7662-T temperature probe, HI70004 pH 4.01 buffer solution sachet, HI70007 pH 7.01 buffer solution sachet, HI700661 electrode cleaning solution sachet (2), HI7071S electrolyte solution (30 mL), HI76404N electrode holder, 12 VDC adapter and instructions.	



HI991300 • HI991301 pH/EC/TDS/Temperature Meters

- ATC (Automatic temperature compensation)
- One to two-point calibration
- BEPS (Battery Error Prevention System)
- Sensor Check™ auto-recognition of all sensors
- Battery life indicator
- On-screen tutorial messages
- HOLD feature freezes readings on the display
- Backlit, graphic LCD display

HI991300 and HI991301 have been designed to offer you pH, conductivity, total dissolved solids and temperature measurements in a slim, lightweight, portable unit.

There are only two buttons, yet users can select from a range of calibration buffers and even the temperature scale (°C or °F). The housing is waterproof and rated for IP67 conditions.

These instruments easily fit in the palm of your hand and the bottom probe connection ensures the electrode cable doesn't get in your way. The large, multi-level LCD simultaneously displays the primary reading, temperature and calibration guides.

HI1288 Multiparameter Probe

The HI1288 multiparameter probe includes pH/EC/TDS and temperature measurements. A solid-state pre-amplifier is integrated into the probe to protect against interference from transient electrical noise.

- pH sensor with extendable cloth junction
 - Cloth junctions allow the user to refresh the junction, effectively increasing the life of the probe
- Amperometric conductivity probe
- Built-in temperature sensor
- Easy to clean sensor



Shown with HI710020 protective boot (optional)

Specifications	HI991300/ HI991301	
pH	Range	0 to 14.00 pH
	Resolution	0.01 pH
	Accuracy	±0.01 pH
	Calibration	automatic, one or two point calibration with two sets of standard buffers (4.01, 7.01, 10.01 or NIST 4.01, 6.86, 9.18)
EC	Range	HI991300: 0 to 3999 µS/cm HI991301: 0.00 to 20.00 mS/cm
	Resolution	HI991300: 1 µS/cm HI991301: 0.01 mS/cm
	Accuracy	±2% F.S.
	Calibration	HI991300: automatic one-point at 1413 µS/cm HI991301: automatic one-point at 12880 µS/cm
TDS	Range	HI991300: 0 to 2000 ppm (mg/L) HI991301: 0.00 to 10.00 ppt (g/L)
	Resolution	HI991300: 1 ppm (mg/L) HI991301: 0.01 ppt (g/L)
	Accuracy	±2% F.S.
	Calibration	HI991300: automatic one-point at 1382 ppm (CONV=0.5) or 1500 ppm (CONV=0.7) HI991301: automatic one-point at 6.44 ppt (CONV=0.5) or 9.02 ppt (CONV=0.7)
	Conversion Factor	selectable from 0.45 to 1.00 with 0.01 increments (default 0.50)
Temperature	Range	0.0 to 60.0°C/32.0 to 140.0°F
	Resolution	0.01°C/0.1°F
	Accuracy	±0.5°C/±1°F
Ordering Information	<p>HI991300 is supplied with HI1288 multiparameter probe, HI70004 pH 4.01 buffer solution sachet, HI70007 pH 7.01 buffer solution sachet, HI70031 1413 µS/cm calibration solution sachet, HI70032 1382 mg/L (ppm) calibration solution sachet, HI700661 electrode cleaning solution sachet, 1.5V AAA batteries, instructions and rugged carrying case.</p> <p>HI991301 is supplied with HI1288 multiparameter probe, HI70004 pH 4.01 buffer sachet, HI70007 pH 7.01 buffer sachet, HI70030 12880 µS/cm calibration solution sachet, HI70038 6.44 g/L (ppt) calibration solution sachet, HI700661 electrode cleaning solution sachet, 1.5V AAA batteries, instructions and rugged carrying case.</p>	



HI98129 • HI98130 pH/EC/TDS Testers

- Waterproof and designed to float
- Automatic one or two-point pH calibration
- ATC (Automatic Temperature Compensation)
- BEPS (Battery Error Prevention System)
- Hold button to freeze readings on the display
- Adjustable TDS conversion factor from 0.45 to 1.00

HI98129 and HI98130 are waterproof testers that offer high accuracy pH/EC/TDS and temperature measurements in a single tester.

These testers feature a replaceable pH electrode cartridge with an extendable cloth junction, as well as an EC/TDS graphite electrode. The extendable cloth junction extends electrode life and the replaceable pH cartridge allows replacement of the pH sensor when exhausted.



- Replaceable pH electrode cartridge

- Calibrate right in our buffer solution sachets

Specifications		HI98129	HI98130
pH	Range	0.00 to 14.00 pH	0.00 to 14.00 pH
	Resolution	0.01 pH	0.01 pH
	Accuracy	±0.05 pH	±0.05 pH
Conductivity	Range	0 to 3999 µS/cm	0.00 to 20.00 mS/cm
	Resolution	1 µS/cm	0.01 mS/cm
	Accuracy	±2% F.S.	±2% F.S.
TDS	Range	0 to 2000 mg/L (ppm)	0.00 to 10.00 g/L (ppt)
	Resolution	1 mg/L (ppm)	0.01 g/L (ppt)
	Accuracy	±2% F.S.	±2% F.S.
Temperature	Range	0.0 to 60.0°C / 32.0 to 140.0°F	0.0 to 60.0°C / 32.0 to 140.0°F
	Resolution	0.1°C / 0.1°F	0.1°C / 0.1°F
	Accuracy	±0.5°C / ±1°F	±0.5°C / ±1°F
Additional Specifications	EC/TDS Calibration	automatic, one-point at 1413 µS/cm or 1382 mg/L (ppm)	automatic, one-point at 12.88 mS/cm or 6.44 g/L (ppt)
	pH Calibration	automatic, one or two points with two sets of standard buffers (pH 4.01 / 7.01 / 10.01 or 4.01 / 6.86 / 9.18)	
Ordering Information	HI98129 (Combo) and HI98130 (Combo) are supplied with HI73127 pH electrode and HI73128 electrode removal tool, batteries and instructions.		



HI98121 pH/ORP Tester

- Waterproof and designed to float
- Automatic one or two point pH calibration
- ATC (Automatic Temperature Compensation)
- BEPS (Battery Error Prevention System)
- HOLD button to freeze readings on the display

The HI98121 is a waterproof pH, ORP and temperature tester that has been completely sealed against humidity and is designed to float.

Electrode replacement with the stainless steel round connector means there are no pins to bend or break during replacement.

When the cloth junction becomes clogged and response time is sluggish, simply pull out 3 mm (1/8") to clear the clogging which will improve response time and stability.



- Cloth extendable junction
 - When the cloth junction becomes dirty from routine testing, simply pull out 3 mm (1/8") to increase response time and stability.

- Exposed temperature sensor
 - The exposed stainless steel temperature sensor facilitates faster and more accurate temperature measurement.

Specifications		HI98121
pH	Range	-2.00 to 16.00 pH
	Resolution	0.01 pH
	Accuracy	±0.05 pH
ORP	Range	± 1000 mV
	Resolution	1 mV
	Accuracy	±2 mV
Temperature	Range	-5.0 to 60.0°C / 23.0 to 140.0°F
	Resolution	0.1°C / 0.1°F
	Accuracy	±0.5°C / ±1°F
Additional Specifications	ORP Calibration	factory calibrated
	pH Calibration	automatic, one or two-point with two sets of standard buffers (pH 4.01 / 7.01 / 10.01 or 4.01 / 6.86 / 9.18)
Ordering Information	HI98121 (pH/ORP) is supplied with HI73127 pH electrode, HI73128 electrode removal tool, 1.5V batteries and instructions.	

HI4113 Nitrate Ion Selective Electrode

For use with compatible
ISE meters

- See a complete list of ISE Solutions on p. 39



Specifications

Type	polymer membrane; combination
Measurement Range	1.0M to 1×10^{-6} M 6200 to 0.62 mg/L (ppm) 1400 to 0.4 mg/L (ppm) as N
Optimum pH Range	3.0 to 8
Temperature Range	0 to 40°C
Approximate Slope	-56 mV
Body O.D.	12 mm
Insertion Length	120 mm
Body Material	PEI/PVC
Cable	1 m coaxial
Connection	BNC

Ordering Information

HI4113 polymer membrane;
combination ISE with 1m coaxial
cable and BNC connection



HI38054 Ozone Test Kit

Specifications

Method	checker disc
Range	0.0-2.3 mg/L (ppm)
Smallest Increment	0.1 mg/L (ppm)
Chemical Method	DPD
# Tests	100 avg.

Ordering Information

HI38054 test kit comes with 100 packets ozone reagent, 500 mL deionized water, checker disc, glass vials with caps (2) and 3 mL plastic pipette.



Parameter Highlight

Nitrate

Nitrate ions can be found in a wide variety of foods, both naturally occurring and as a food additive. Small concentrations of nitrate occur naturally in fruits and vegetables; nitrate is taken into the plant from the soil as a source of nitrogen. The concentration of naturally occurring nitrates is dependent upon growing conditions, where factors include the use of fertilizer, soil characteristics, light intensity and exposure, water availability and presence of nitrate in the water itself. Nitrates are also used as food additives, especially in processed meats such as sausages. Typically added as sodium or potassium salts, nitrate prevents bacterial growth, preserves coloring and extends the shelf life of foods. Public health concerns exist regarding the effects of nitrates and its derived compounds in food. Excessive amounts of nitrate can cause illness in both infants and adults. In response, the Joint Expert Committee on Food Additives (JECFA) of the Food and Agriculture Organization (FAO) and World Health Organization (WHO) reviewed and recognized safety guidelines. JECFA established an acceptable daily intake of 0 to 3.7 milligrams of nitrate per kilogram of body weight. Nitrates can be easily measured in food with a nitrate ion selective electrode (ISE), which is proven as a reliable and accurate measurement technique for food applications. With a durable PEI/PVC probe body and replaceable polymer membrane sensor, the nitrate ISE can be used with Hanna's benchtop meters in a wide variety of food industries.

edge®

Hanna Instruments is proud to introduce the world's most innovative pH, EC and DO meter... edge®

edge® is thin and lightweight, measuring just 1/2" thick and weighing less than 9 ounces. edge® has an incredibly wide viewing angle, 5.5" LCD and a sensitive capacitive touch keypad.

edge® measures pH, conductivity and dissolved oxygen through its unique digital electrodes. These digital electrodes are auto-recognized, providing sensor type, calibration data and a serial number when connected to edge® by an easy to plug-in 3.5mm connector. The versatile design of edge® enables it to be used as a handheld, benchtop or wall-mounted meter. edge® simplifies measurement, configuration, calibration, diagnostics, logging and transferring data directly to a computer or USB drive.

edge® features Hanna's exclusive CAL Check™ to warn you if the electrode you are using is not clean or if your buffers are contaminated during calibration. We have added Sensor Check™ for pH sensors with a matching pin. Our Sensor Check™ feature warns you if the pH bulb is cracked and/or the junction of the electrode is compromised.



- Simply connect each probe via the 3.5 mm jack; Digital Smart Electrodes are automatically recognized

- **Large, easy to read LCD**
 - edge® features a 5.5" LCD display with 150° viewing angle.
- **Clear, full text readout**
 - edge® features guides displayed on the bottom of the screen, so there is no need to decipher scrambled abbreviations or symbols; these helpful messages guide you through every process quickly and easily.
- **Sleek design**
 - Measuring just 1/2" thick and weighing just 8.8 ounces, the edge® is incredibly thin and lightweight.
- **Capacitive touch buttons**
 - edge® features a capacitive touch keypad that cannot be clogged with sample residue. For faster scrolling, simply hold down the arrow keys.



3 Kit Configurations

0 footprint 0.5 inch thick 8.8 oz. weight 8 hours battery life 5.5 inch display 2 USB ports

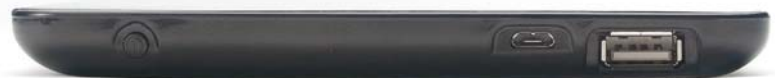

- **Basic mode**
 - In basic mode, edge® provides a simplified screen layout and features.
- **GLP**
 - Data from the last performed calibration is stored in the sensor, including the electrode's offset, slope, date, time and buffer/standards. When the sensor is connected to edge®, GLP data is automatically transferred.
- **Data logging**
 - edge® allows you to store up to 1000 log records of data (200 records log-on-demand, 600 records interval). Logging data sets include readings, GLP data, date and time.
- **Two USB ports**
 - edge® includes one standard USB port for exporting data with a flash drive and one micro USB port for computer connection and for charging when the cradle is not available.
- **3.5 mm probe input**
 - Plugging an electrode in has never been simpler; no alignments or broken pins, simply connect the 3.5 mm plug and begin.
- **Cradle and electrode holder**
 - edge® is equipped with a benchtop cradle with an adjustable swivel electrode holder to charge and secure edge® in place at the optimum viewing angle.
- **Portable field unit**
 - The edge® is ideal for field use due to its light weight, large screen and thin design. It can be slipped into a backpack or messenger bag.
- **Wall mount cradle**
 - The included wall mount cradle makes it easy to conserve space on the benchtop and can charge edge® with the AC adapter. Ideal for continuous monitoring applications.

pH

- Resolution selectable from 0.01 and 0.001 pH
- Range -2.000 to 16.000 pH
- Accuracy ±0.002 pH
- Data logging
 - Manual log-on-demand, manual log on stability, interval logging
- Automatic Temperature Compensation
- CAL Check™ Indicators:
 - Probe condition, response time, check buffer, clean electrode
- Sensor Check™ Indicators:
 - Broken electrode, Clogged junction
- GLP data
 - Records date, time, offset, slope and buffers
- Five point calibration
- Calibration tag on screen
 - Identifies buffers used for current calibration
- Calibration expiration warning

Conductivity

- Four-ring platinum probe
 - Covers all ranges from 0.00 µS/cm to 500 mS/cm (absolute EC)
- Accuracy
 - ± 1% of the reading ± (0.05 µS/cm or 1 digit, whichever is greater)
- Calibration
 - Offset (0 µS/cm) and cell factor calibration
 - Choice of 5 standards
- Auto-ranging or manual range selection
- EC, TDS and salinity reading modes
- Temperature compensation
 - Automatic
 - NoTC (absolute)
- GLP data
 - Records date, time, offset and cell constant value (K)
- Adjustable EC to TDS conversion factor
- Adjustable temperature correction coefficient

Dissolved Oxygen

- Clark type polarographic probe with easy-to-replace membrane cap
 - Covers all ranges from 0.00 to 45.00 mg/L (ppm); 0.0 to 300% oxygen saturation
- Accuracy ±1.5% full scale
- One or two-point calibration (HI7040 solution); 0% and 100% (air)
- Automatic Temperature Compensation from 0 to 50 °C
- GLP data
 - Records date, time, calibration standards, altitude value and salinity value
- Altitude compensation from -500 to 4000 meters (-1640 to 13,123')
- Salinity compensation 0 to 40g/L

Specifications

edge®

pH (using pH kit)	Range	basic mode: -2.00 to 16.00 pH; ±1000.0 mV for pH standard mode: -2.00 to 16.00 pH; -2.000 to 16.000 pH; ±1000.0 mV for pH		
	Resolution	0.01 pH; 0.001 pH; 0.1 mV		
	Accuracy (@25°C/77°F)	±0.01 pH; ±0.002 pH; ±0.2 mV		
	Calibration Points	five in standard mode; three in basic mode		
	Calibration Buffers	standard mode: 1.68, 4.01, 6.86, 7.01, 9.18, 10.01, 12.45 and two custom buffers basic mode: 4.01, 6.86, 7.01, 9.18, 10.01		
EC (using EC kit)		EC	TDS	Salinity
	Range	0.00 to 29.99 µS/cm; 30.0 to 299.9 µS/cm; 300 to 2999 µS/cm; 30.0 to 200.0 mS/cm; up to 500.0 mS/cm (absolute EC)*	0.00 to 14.99 mg/L (ppm); 15.0 to 149.9 mg/L (ppm); 150 to 1499 mg/L (ppm); 1.50 to 14.99 g/L; 15.0 to 100.0 g/L; up to 400.0 g/L (absolute TDS)*, with 0.80 conversion factor	0.0 to 400.0 % NaCl; 0.01 to 42.00 PSU 0.0 to 80.0 g/L
	Resolution	0.01 µS/cm; 0.1 µS/cm; 1 µS/cm; 0.01 mS/cm; 0.1 mS/cm	0.01 ppm; 0.1 ppm; 1 ppm; 0.01 g/L; 0.1 g/L (0.80 TDS factor)	0.1 % NaCl; 0.01 PSU; .01 g/L
	Accuracy (@25°C/77°F)	±1% of reading ±(0.5 µS or 1 digit, whichever is greater)	±1% of reading ±(0.03 ppm or 1 digit, whichever is greater)	±1% of reading
	Calibration	one-point offset calibration (0.00 µS/cm in air); one-point slope calibration in EC standard 84 µS/cm, 1413 µS/cm, 5.00 mS/cm, 12.88 mS/cm, 80.0 mS/cm and 118.8 mS/cm	through EC calibration	one-point with HI7037L 100% NaCl sea water standard (other scales through EC calibration)
	TDS Factor	0.40 to 0.80		
DO (using DO kit)	Range	0.00 to 45.00 ppm; 0.0 to 300.0 % saturation		
	Resolution	0.01 ppm; 0.1 % saturation		
	Accuracy	± 1.5% of reading ±1 digit		
	Calibration Points	one or two-point at 0% (HI7040 solution) and 100% (in air)		
Temperature	Range	-20.0 to 120.0°C; -4.0 to 248.0°F		
	Resolution	0.1°C; 0.1°F		
	Accuracy	±0.2°C; ±0.4 °F		

Ordering Information

edge® is available in 3 kit configurations: pH, EC and DO

All Kits Include: edge®, benchtop docking station with electrode holder, wall-mount cradle, USB cable, 5 VDC power adapter and instruction manual.

HI2020-01 (115V) pH kit also includes: HI11310 Glass body, refillable pH electrode with temperature sensor, 2 sachets of pH 4 buffer solutions, 2 sachets of pH 7 buffer solutions, 2 sachets of pH 10 buffer solutions, electrode cleaning solutions and quality certificate.

HI2030-01 (115V) EC kit also includes: HI763100 Conductivity probe, 3 sachets of 1413 µS/cm conductivity standard, 3 sachets of 12880 µS/cm conductivity standard and quality certificate.

HI2040-01 (115V) DO kit also includes: HI764080 Dissolved Oxygen electrode, HI7041S Refill electrolyte solution, 2 DO membrane caps, 2 DO membrane cap o-rings and quality certificate.

*Uncompensated temperature reading



HI5221 • HI5222 Research Grade Meters

with CAL Check™

- CAL Check™ and calibration reminder
- Five-point pH and ISE (HI5222) calibration
- Automatic or manual temperature compensation
- GLP features—Meets Good Laboratory Practices
- 100 lot logging with 10,000 records/lot
- On-screen tutorials and directions
- Up to 10 user profiles can be saved and recalled
- Automatic, log-on-demand and AutoHold logging
- PC compatible via USB with HI92000 software
- ISE incremental methods (HI5222)
- Multiple input channels (HI5222)
- Capacitive touch keypad

HI5221 and HI5222 are research grade pH, mV and temperature benchtop meters. HI5222 is a dual channel meter with two independent inputs for pH, ORP and ISE probes. Each channel has its own temperature input and supports half-cells with a separate reference electrode input.

Specifications	HI5221/HI5222	
pH	Range	-2.000 to 20.000 pH
	Resolution	0.1 pH; 0.01 pH; 0.001 pH
	Accuracy	±0.1 pH; ±0.01 pH; ±0.002 pH ±1 LSD
	Calibration	automatic, up to five point calibration, eight standard buffers available (1.68, 3.00, 4.01, 6.86, 7.01, 9.18, 10.01, 12.45), and five custom buffers
mV	Range	±2000 mV
	Resolution	0.1 mV
	Accuracy	±0.2 mV ±1 LSD
Temperature	Range	-20.0 to 120.0°C; -4.0 to 248.0°F; 253.15 to 393.15K
	Resolution	0.1°C; 0.1°F; 0.1K
	Accuracy	±0.2°C; ±0.4°F; ±0.2K
ISE (HI5222 Only)	Range	1 x 10 ⁻⁶ to 9.99 x 10 ¹⁰ concentration
	Resolution	1; 0.1; 0.01; 0.001 concentration
	Accuracy	±0.5% (monovalent ions); ±1% (divalent ions)
Ordering Information	Calibration	automatic, up to five-point calibration, five fixed standard solutions available (0.1, 1, 10, 100, 1000 ppm), and five user defined standards
	HI5221-01 (115V) and HI5222-01 (115V) are supplied with HI1131B pH electrode, HI7662-T temperature probe, HI76404N electrode holder, HI70004 pH 4.01 buffer solution sachet, HI70007 pH 7.01 buffer solution sachet, HI700661 electrode cleaning solution sachet (2), HI7071S electrolyte solution (30 mL), 12 VDC adapter and instructions.	



HI3220 pH Benchtop Meter

pH, mV and Temperature

- Up to five-point pH calibration
- Automatic or manual pH temperature compensation
- GLP Features—Meets Good Laboratory Practices
- Stability, interval and log-on-demand data logging
- Up to 400 log-on-demand records and 600 automatic logging records
- PC connectivity via USB and HI92000 software
- On-screen tutorials

The HI3220 professional benchtop meter with graphic LCD is designed to provide accurate laboratory results.

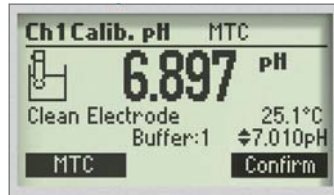

- CAL Check™
 - pH calibration features detailed CAL Check™ messages. Users are guided through the calibration procedure with step-by-step on-screen instructions.

Specifications	HI3220	
pH	Range	-2.0 to 20.0; -2.00 to 20.00; -2.000 to 20.000
	Resolution	0.1; 0.01; 0.001
	Accuracy	±0.01; ±0.002
Calibration	up to five-point calibration, seven standard buffers available (1.68, 4.01, 6.86, 7.01, 9.18, 10.01, 12.45) + five custom buffers	
	Range	±2000 mV
mV	Resolution	0.1 mV
	Accuracy	±0.2 mV
	Range	-20.0 to 120.0 °C; -4.0 to 248.0 °F
Temperature	Resolution	0.1°C; 0.1°F
	Accuracy	±0.2°C; ±0.4°F (excluding probe error)
	Ordering Information	HI3220-01 (115V) is supplied with HI1131B pH electrode, HI7662-T temperature probe, HI76404N electrode holder, HI70004 pH 4.01 buffer solution sachet, HI70007 pH 7.01 buffer solution sachet, HI700661 electrode cleaning solution sachet (2), HI7071S electrolyte solution (30 mL), 12 VDC adapter and instructions.

HI98190 • HI98191 Waterproof Meters

pH/ORP/ISE

- CAL Check™
- Log-on-demand up to 200 samples (HI98190) or up to 300 samples (HI98191)
- Five point pH calibration
- Up to ± 0.002 pH accuracy and ± 0.001 pH resolution
- Backlit, graphic LCD display
- Dedicated HELP key
- GLP Features—Meets Good Laboratory Practices
- IP67 waterproof protection for field use
- BEPS (Battery Error Prevention System)
- Battery life indicator
- PC connectivity via USB with HI92000 software and HI920015 USB cable



HI98190 and HI98191 are waterproof, portable meters designed for demanding applications. HI98190 measures pH/mV and temperature while the HI98191 also includes ISE measurements. Ideal for field use, these meters come equipped with a pH/temperature electrode with titanium casing.

ISE Sensors and Calibration (HI98191)

HI98191 has 15 different ISE sensors pre-programmed in the meter. Selecting the appropriate sensor will automatically update the ion charge for slope calibration and can be calibrated up to five points with the choice of seven standard buffers and five custom buffers. This meter allows an extensive choice of measurement units (ppm, ppt, g/L, ppb, $\mu\text{g/L}$, mg/mL, M, mol/L, mmol/L, % w/v, user).

Specifications	HI98190/HI98191	
pH	Range	-2.0 to 20.0 pH; -2.00 to 20.00 pH; -2.000 to 20.000 pH
	Resolution	0.1 pH; 0.01 pH; 0.001 pH
	Accuracy	± 0.1 pH; ± 0.01 pH; ± 0.002 pH
	Calibration	up to five-point calibration, seven standard buffers available (1.68, 4.01, 6.86, 7.01, 9.18, 10.01, 12.45) and five custom buffers
mV	Range	± 2000 mV
	Resolution	0.1 mV
	Accuracy	± 0.2 mV
Temperature	Range	-20.0 to 120.0 °C; -4.0 to 248.0 °F
	Resolution	0.1°C; 0.1°F
	Accuracy	± 0.4 °C; ± 0.8 °F
ISE (HI98191 only)	Range	from 1.00 E^{-7} to 9.99 E^{10} concentration (choice of units)
	Resolution	3 digits 0.01; 0.1; 1; 10 concentration
	Accuracy	$\pm 0.5\%$ of reading (monovalent ions), $\pm 1\%$ of reading (divalent ions)
	Calibration	up to five point calibration, six standard solutions (in units selected)
Ordering Information	HI98190 and HI98191 are supplied with HI12963 pH electrode (HI98190-01), HI72911B pH electrode (HI98191-01), HI7004M pH 4.01 buffer solution (230 mL), HI7007M pH 7.01 buffer solution (230 mL), electrode general cleaning solution sachet (2), 100 mL plastic beaker (2), HI92000 PC software, HI920015 micro USB cable, 1.5V AA batteries (4), instruction manual, quick start guide, quality certificate and rugged carrying case.	

HI9126 Portable pH Meter

CAL Check™

- CAL Check™
- Backlit, multi-level LCD display
- BEPS (Battery Error Prevention System)
- Battery life indicator
- Help feature



The HI9126 includes Hanna's exclusive CAL Check™ technology. CAL Check™ monitors the pH bulb and reference junction of the electrode every time the instrument is calibrated. In the event of a dirty pH electrode, CAL Check™ warns users that maintenance may be needed.

Calibrated buffers are continuously displayed in measurement mode to remind users of the instrument's calibration point. Users can easily determine if readings are taken too far outside the calibration range.

The HI9126 can store and recall readings at the touch of a button and features a real-time clock.

HI9126 utilizes the HI1230B double junction pH electrode. The double junction design helps to minimize junction contamination for consistently accurate results. The HI9126 can also measure ORP in the mV range using an optional ORP probe.

Specifications

pH	Range	-2.00 to 16.00
	Resolution	0.01
	Accuracy	± 0.01
pH Calibration	Resolution	automatic, one or two-point with seven memorized buffer values (pH 1.68, 4.01, 6.86, 7.01, 9.18, 10.01, 12.45) + 2 custom buffers
	Accuracy	± 0.2 mV; ± 1 mV
mV	Range	± 699.9 mV; ± 1999 mV
	Resolution	0.1 mV; 1 mV
Temperature	Range	-20.0 to 120.0°C; -4.0°F to 248.0°F
	Resolution	0.1°C; 0.1°F
	Accuracy	± 0.4 °C; ± 0.8 °F
Ordering Information	HI9126 is supplied with HI1230B pH electrode, HI7662 temperature probe, HI70004 pH 4.01 buffer solution sachet, HI70007 pH 7.01 buffer sachet, HI700661 electrode cleaning solution sachet, 100 mL plastic beaker, 1.5V AAA batteries, instructions and hard carrying case.	

HI991001 • HI991003 pH/pH-mV/ORP and Temperature Meters

with Sensor Check™

- Sensor Check™ (HI991003)
- Automatic Temperature Compensation
- Up to two-point automatic calibration
- BEPS (Battery Error Prevention System)
- Compact, heavy-duty, and waterproof protected casing
- Battery life indicator
- Tutorial messages displayed on LCD

HI991001 is a portable pH/temperature meter while the HI991003 is a portable pH/pH-mV/ORP/temperature meter with our unique Sensor Check™ feature that allows the user to determine the electrode status at any time.

- Pre-amplified pH electrodes
 - The HI1297D (HI991003) pH/ORP and HI1296D (HI991001) pH electrodes have an internal temperature sensor and also contain a pre-amplifier to render measurements impervious to noise and electrical interferences.



HI99161 HACCP pH Meter

for Food and Dairy

- Automatic Temperature Compensation
- Up to two-point automatic calibration
- Compact, heavy-duty, and waterproof protected casing
- BEPS (Battery Error Prevention System)
- Battery life indicator
- Tutorial messages displayed on LCD
- Specialized electrode
 - The FC202D is the ideal electrode to measure the pH of milk, yogurt, meats, cheeses, fruit, sushi, rice, jams, jellies, dough, ice cream, yogurt, beverages and juice



Shown with HI710024 protective boot (optional)

The HI99161 is a portable pH and temperature meter designed specifically for dairy applications. Monitoring pH in the dairy process is critical to ensure the quality is upheld.

The FC202D pH electrode features a rugged, easy to clean PVDF body with a conical tip making it ideal for measurements in semi-solids such as meats and cheeses.

Specifications HI991001/HI991003

pH	Range	-2.00 to 16.00
	Resolution	0.01
	Accuracy	±0.02
mV (HI991003)	Range	±1999 mV
	Resolution	1 mV
	Accuracy	±2 mV
pH-mV (HI991003)	Range	±825 mV (pH-mV)
	Resolution	1 mV
	Accuracy	±1 mV

Ordering Information

HI991001 is supplied with HI1296D pH/ORP probe with internal temperature sensor, HI70004 pH 4.01 buffer sachet, HI70007 pH 7.01 buffer sachet, HI700661 electrode cleaning solution sachet (2), 1.5V AAA batteries, instructions and rugged carrying case.

HI991003 is supplied with HI1297D pH/ORP probe with internal temperature sensor, HI70004 pH 4.01 buffer sachet, HI70007 pH 7.01 buffer sachet, HI700661 electrode cleaning solution sachet (2), 1.5V AAA batteries, instructions and rugged carrying case.

Specifications HI99161

pH	Range	-2.00 to 16.00
	Resolution	0.01
	Accuracy	±0.02
Temperature	Calibration	automatic one or two-point calibration with two sets of memorized buffers (Standard 4.01, 7.01, 10.01 or NIST 4.01, 6.86, 9.18)
	Range	-5.0 to 105.0°C; 23.0 to 221.0°F
	Resolution	0.1°C; 0.1°F
Accuracy	±0.5°C (up to 60°C), ±1.0°C (outside) / ±1.0°F (up to 140°F); ±2.0°F (outside)	

Ordering Information

HI99161 is supplied with FC202D pH/temperature probe, HI70004 pH 4.01 buffer solution sachet, HI70007 pH 7.01 buffer solution sachet, HI700642 electrode cleaning solution sachets (2), 1.5V AAA batteries, instructions and hard carrying case.



HI99163 Portable pH Meter

HACCP Compliant for Meat

- Automatic Temperature Compensation
- Automatic calibration up to two-points
- Compact, heavy-duty, and waterproof protected casing
- BEPS (Battery Error Prevention System)
- Battery life indicator
- Tutorial messages displayed on LCD
- Specialized meat electrode
 - The FC232D pre-amplified pH electrode with removable stainless steel blade enables non-intrusive measurements of meat products inside and out. The free diffusion junction helps to avoid a clogged reference and the external body material is non-toxic and food compatible.

- Two blade lengths available
 - Use the optional FC098 (20 mm) or the included FC099 (35 mm) stainless steel meat penetration blades for meat processing applications.



Specifications	HI99163	
pH	Range	-2.00 to 16.00
	Resolution	0.01
	Accuracy	±0.02
Temperature	Calibration	automatic one or two-point calibration with two sets of memorized buffers (Standard 4.01, 7.01, 10.01 or NIST 4.01, 6.86, 9.18)
	Range	-5.0 to 105.0°C; 23.0 to 221.0°F
	Resolution	0.1°C/0.1°F
Accuracy	Accuracy	±0.5°C (up to 60°C), ±1.0°C (outside) / ±1.0°F (up to 140°F); ±2.0°F (outside)
	Accuracy	±0.5°C (up to 60°C), ±1.0°C (outside) / ±1.0°F (up to 140°F); ±2.0°F (outside)
Ordering Information	<p>HI99163 is supplied with FC232D pH/ temperature probe with FC099 stainless steel blade tip, HI70004 pH 4.01 buffer solution sachet, HI70007 pH 7.01 buffer solution sachet, HI700630 electrode acid cleaning solution sachets for meat, grease and fats (2), 1.5V AAA batteries, instructions and hard carrying case.</p>	

HI98127 (pHep®4) • HI98128 (pHep®5) pH/Temperature Testers

- Waterproof and designed to float
- Automatic Temperature Compensation
- Hold button to freeze readings on the display
- BEPS (Battery Error Prevention System)
- Automatic calibration

The pHep®4 and pHep®5 testers are for users that require the greatest accuracy and features while staying economical.



- Replaceable pH electrode with stainless steel round connector
- Calibrate right in our buffer solution sachets

Specifications	HI98127 (pHep®4)	HI98128 (pHep®5)	
pH	Range	-2.0 to 16.0 pH	-2.00 to 16.00 pH
	Resolution	0.1 pH	0.01 pH
	Accuracy	±0.1 pH	±0.05 pH
	Calibration	automatic, at one or two-point with two sets of standard buffers (pH 4.01 / 7.01 / 10.01 or pH 4.01 / 6.86 / 9.18)	
Temperature	Range	-5.0 to 60.0°C / 23.0 to 140.0°F	-5.0 to 60.0°C / 23.0 to 140.0°F
	Resolution	0.1°C; 0.1°F	0.1°C; 0.1°F
	Accuracy	±0.5°C; ±1°F	±0.5°C; ±1°F
Ordering Information	<p>HI98127 (pHep®4) and HI98128 (pHep®5) are supplied with HI73127 pH electrode, HI73128 electrode removal tool, 1.5V batteries and instructions.</p>		



HI98108 pHep®+ pH Tester

- Renewable junction
- Automatic Temperature Compensation

With a renewable cloth junction, the pHep®+ has an extended life over typical pH testers.

Specifications	HI98108 (pHep®+)
Range	0.0 to 14.0 pH
Resolution	0.1 pH
Accuracy (@20°C/68°F)	±0.1 pH
Calibration	manual, two-point
Ordering Information	<p>HI98108 (pHep®+) is supplied with protective cap, calibration screwdriver, batteries and instructions.</p>



Specifications		HI1131B
Reference		double, Ag/AgCl
Junction / Flow Rate		ceramic, single / 15-20 µL/h
Electrolyte		KCl 3.5M
Max Pressure		0.1 bar
Range		pH: 0 to 13
Recommended Operating Temp.		0 to 100°C (32 to 212°F)
Tip / Shape		spheric (dia: 9.5 mm)
Temperature Sensor		no
Amplifier		no
Body Material		glass
Ordering		HI1131B combination, refillable pH electrode with 1m (3.3') coaxial cable and BNC connection



Specifications		HI1053B
Reference		double, Ag/AgCl
Junction / Flow Rate		ceramic, triple / 40-50 µL/h
Electrolyte		KCl 3.5M
Max Pressure		0.1 bar
Range		pH: 0 to 12
Recommended Operating Temp.		-5 to 100°C (23 to 212°F)
Tip / Shape		conic (12 x 12 mm)
Temperature Sensor		no
Amplifier		no
Body Material		glass
Ordering		HI1053B combination, refillable pH electrode with conical tip, 1m (3.3') coaxial cable and BNC connection



Specifications		FC100B
Reference		double, Ag/AgCl
Junction / Flow Rate		ceramic, single / 15-20 µL/h
Electrolyte		KCl 3.5M
Max Pressure		0.1 bar
Range		pH: 0 to 13
Recommended Operating Temp.		0 to 80°C (32 to 176°F)
Tip / Shape		spheric (dia: 7.5 mm)
Temperature Sensor		no
Amplifier		no
Body Material		PVDF
Ordering		FC100B pH electrode with 1m (3.3') coaxial cable and BNC connection



Specifications		FC200B
Reference		single, Ag/AgCl
Junction / Flow Rate		open
Electrolyte		viscolene
Max Pressure		0.1 bar
Range		pH: 0 to 12
Recommended Operating Temp.		0 to 50°C (32 to 122°F)
Tip / Shape		conic (6 x 10 mm)
Temperature Sensor		no
Amplifier		no
Body Material		PVDF
Ordering		FC200B pH electrode with PVDF outer body, conical tip, 1m (3.3') coaxial cable and BNC connection



Specifications		FC230B
Reference		single, Ag/AgCl
Junction / Flow Rate		open
Electrolyte		viscolene
Max Pressure		0.1 bar
Range		pH: 0 to 12
Recommended Operating Temp.		0 to 50°C (32 to 122°F)
Tip / Shape		conic (6 x 10 mm)
Temperature Sensor		no
Amplifier		no
Body Material		PVDF
Ordering		FC230B combination pH electrode with PVDF outer body, 1m (3.3') coaxial cable and BNC connection



FC098 and FC099 stainless steel blades for meat penetration (optional)



Specifications		FC210
Reference		double, Ag/AgCl
Junction / Flow Rate		open
Electrolyte		viscolene
Max Pressure		0.1 bar
Range		pH: 0 to 12
Recommended Operating Temp.		0 to 50°C (32 to 122°F)
Tip / Shape		conic (12 x 12 mm)
Temperature Sensor		no
Amplifier		no
Body Material		glass
Ordering		FC210 combination, refillable pH electrode with conical tip, 1m (3.3') coaxial cable and BNC connection



Specifications	FC240B
Reference	single, Ag/AgCl
Junction / Flow Rate	open
Electrolyte	viscolene
Max Pressure	0.1 bar
Range	pH: 0 to 13
Recommended Operating Temp.	0 to 50°C (32 to 122°F)
Tip / Shape	conic (3 x 5 mm)
Temperature Sensor	no
Amplifier	no
Body Material	AISI 316
Ordering	FC240B combination, pH electrode with AISI stainless steel sheath, conical tip, 1m (3.3') coaxial cable and BNC connection



CPSTM (Clogging Prevention System)

Specifications	HI1048B
Reference	double, Ag/AgCl
Junction / Flow Rate	open, CPSTM
Electrolyte	KCl 3.5M
Max Pressure	0.1 bar
Range	pH: 0 to 12
Recommended Operating Temp.	0 to 80°C (32 to 176°F)
Tip / Shape	spheric (dia: 8 mm)
Temperature Sensor	no
Amplifier	no
Body Material	glass
Ordering	HI1048B CPSTM (Clogging Prevention System) pH electrode with 1m (3.3') coaxial cable and BNC connection

edge® Electrodes

Digital Smart Electrodes

The electrodes used with edge® are nearly as advanced as edge® itself. They feature a built-in microchip that stores sensor type, ID, and calibration information that is automatically retrieved by edge® once the electrode is plugged in.

Stored pH calibration information includes: calibrated buffers, date, time, offset and slope characteristics of the electrode. Conductivity calibration information includes: calibrated conductivity standards, date, time, and cell constant of the sensor. Dissolved oxygen calibration information includes: standards used for calibration, date, time, altitude and salinity correction.

These digital electrodes also feature an easy to plug in 3.5 mm connector so you never have to worry about the right angle or aligning pin settings.



Specifications	HI11310
Reference	double, Ag/AgCl
Junction / Flow Rate	ceramic, single / 15-20 µL/h
Electrolyte	KCl 3.5M
Max Pressure	0.1 bar
Range	pH: 0 to 13
Recommended Operating Temp.	-5 to 100°C (23 to 212°F)
Tip / Shape	spheric (dia: 9.5 mm)
Temperature Sensor	yes
Matching Pin	no
Amplifier	yes
Body Material	glass
Ordering	HI11310 combination, refillable pH electrode with 1m (3.3') coaxial cable and 3.5mm jack connection for edge®



Sensor Check™

Specifications	HI11311
Reference	double, Ag/AgCl
Junction / Flow Rate	ceramic, single / 15-20 µL/h
Electrolyte	KCl 3.5M
Max Pressure	0.1 bar
Range	pH: 0 to 13
Recommended Operating Temp.	-5 to 100°C (23 to 212°F)
Tip / Shape	spheric (dia: 9.5 mm)
Temperature Sensor	yes
Matching Pin	yes
Amplifier	yes
Body Material	glass
Ordering	HI11311 combination, refillable pH electrode with matching pin, 1m (3.3') coaxial cable and 3.5mm jack connection for edge®



Sensor Check™ (HI12301 and HI11311 only)

When used with Hanna edge® compatible electrodes equipped with a matching pin, edge® checks the impedance of the pH measuring electrode in real-time to notify you in the event of glass breakage.

During calibration, Sensor Check™ technology checks the state of the junction. The reference junction is also evaluated and reported on the display.



Specifications		HI12300
Reference		double, Ag/AgCl
Junction / Flow Rate		ceramic, single / 15-20 µL/h
Electrolyte		gel
Max Pressure		2 bar
Range		pH: 0 to 13
Recommended Operating Temp.		-5 to 70°C (23 to 158°F)
Tip / Shape		spheric (dia: 7.5 mm)
Temperature Sensor		yes
Matching Pin		no
Amplifier		yes
Body Material		PEI
Ordering		HI12300 combination pH electrode with 1m (3.3') coaxial cable and 3.5mm jack connection for edge®



Sensor Check™

Specifications		HI12301
Reference		double, Ag/AgCl
Junction / Flow Rate		ceramic, single / 15-20 µL/h
Electrolyte		gel
Max Pressure		2 bar
Range		pH: 0 to 13
Recommended Operating Temp.		-5 to 70°C (23 to 158°F)
Tip / Shape		spheric (dia: 7.5 mm)
Temperature Sensor		yes
Matching Pin		yes
Amplifier		yes
Body Material		PEI
Ordering		HI12301 combination pH electrode with matching pin, 1m (3.3') coaxial cable and 3.5mm jack connection for edge®



Specifications		HI10530
Reference		double, Ag/AgCl
Junction / Flow Rate		ceramic, triple / 40-50 µL/h
Electrolyte		KCl 3.5M
Max Pressure		0.1 bar
Range		pH: 0 to 13
Recommended Operating Temp.		-5 to 100°C (23 to 212°F)
Tip / Shape		conic (12 x 12 mm)
Temperature Sensor		yes
Matching Pin		no
Amplifier		yes
Body Material		glass
Ordering		HI10530 combination, refillable pH electrode with conical tip, 1m (3.3') coaxial cable and 3.5mm jack connection for edge®



CPS™ (Clogging Prevention System)

Specifications		HI10480
Reference		double, Ag/AgCl
Junction / Flow Rate		open/CPS™
Electrolyte		KCl 3.5M
Max Pressure		0.1 bar
Range		pH: 0 to 12
Recommended Operating Temp.		0 to 80°C (32 to 176°F)
Tip / Shape		round (dia: 8 mm)
Temperature Sensor		yes
Matching Pin		no
Amplifier		yes
Body Material		glass
Ordering		HI10480 CPS™ (Clogging Prevention System) pH electrode, 1m (3.3') coaxial cable and 3.5mm jack connection for edge®



Specifications		FC2100
Reference		double, Ag/AgCl
Junction / Flow Rate		open/continuous
Electrolyte		viscolene
Max Pressure		0.1 bar
Range		pH: 0 to 12
Recommended Operating Temp.		0 to 60°C (32 to 140°F)
Tip / Shape		conic (12 x 12 mm)
Temperature Sensor		yes
Matching Pin		no
Amplifier		yes
Body Material		glass
Ordering		FC2100 pH electrode with conical tip, 1m (3.3') coaxial cable and 3.5mm jack connection for edge®



Specifications		FC2320
Reference		single, Ag/AgCl
Junction / Flow Rate		open/continuous
Electrolyte		viscolene
Max Pressure		0.1 bar
Range		pH: 0 to 12
Recommended Operating Temp.		0 to 60°C (32 to 140°F)
Tip / Shape		conic (6 x 10 mm)
Temperature Sensor		yes
Matching Pin		no
Amplifier		yes
Body Material		glass
Ordering		FC2100 pH electrode with conical tip, 1m (3.3') coaxial cable and 3.5mm jack connection for edge®





HI5000 Series pH Technical Calibration Solutions

Precise Measurements

To obtain precise and valid pH measurements, the pH meter and pH electrode must be calibrated at a minimum of two points, bracketing the value of the sample to be tested.

Technical Solutions (± 0.01 pH) for Each Point of the pH Scale

This complete scale of buffer solutions offers a higher degree of accuracy for pH measurements in specific areas of application, such as in monitoring the pH of must and wine. This line includes twenty solutions starting from a value of pH 1.00 up to pH 13.00 with an accuracy of ± 0.01 pH, thus covering every point of the pH scale.

Certificate of Analysis

These solutions are dedicated to applications that require extremely accurate pH monitoring, and come with a certificate of analysis prepared by comparison against NIST standards.

Color Coded

Also available are solution bottles that are colored according to a given standard calibration value: HI5004-R (Red), HI5007-G (Green) and HI5010-V (Violet).

pH Value @25°C	Code	Size	Package
4.01	HI5004	500 mL	bottle
4.01	HI5004-01	1 L	bottle
4.01	HI5004-R	500 mL	bottle, color coded
4.01	HI5004-R08	1 G (3.78 L) (2)	bottle, color coded
7.01	HI5007	500 mL	bottle
7.01	HI5007-01	1 L	bottle
7.01	HI5007-G	500 mL	bottle, color coded
7.01	HI5007-G08	1 G (3.78 L) (2)	bottle, color coded
10.01	HI5010	500 mL	bottle
10.01	HI5010-01	1 L	bottle
10.01	HI5010-V	500 mL	bottle, color coded
10.01	HI5010-V08	1 G (3.78 L) (2)	bottle, color coded

HI7000 Series pH Standard Calibration Solutions

All pH solutions show batch number, expiration date and the correlation table between pH and temperature.

4.01 pH Buffer Solution @ 25°C

This buffer value is widely used in water purification plants, in the food industry and wherever the pH is expected to be slightly acidic.

7.01 pH Buffer Solution @ 25°C

pH 7.01 is the most widely used among all buffer solutions. For this reason we have prepared it in a wider variety of sizes to meet application demand.

8.20 and 8.30 pH Buffer Solution @ 25°C

To increase accuracy of your measurement, Hanna offers both 8.20 pH and 8.30 pH buffer solution.

10.01 pH Buffer Solution @ 25°C

pH 10.01 solution is commonly used to calibrate equipment used for analyzing basic samples.

pH Value @25°C	Code	Size	Package
4.01	HI7004/1G	1 gallon (3.78 L)	bottle
4.01	HI7004/1L	1 L	bottle
4.01	HI7004L	500 mL	bottle
7.01	HI7007/1G	1 gallon (3.78 L)	bottle
7.01	HI7007/1L	1 L	bottle
7.01	HI7007L	500 mL	bottle
8.20	HI70082M	230 mL	bottle
8.30	HI70083M	230 mL	bottle
10.01	HI7010/1G	1 gallon (3.78 L)	bottle
10.01	HI7010/1L	1 L	bottle
10.01	HI7010L	500 mL	bottle

General Cleaning, Storage and Refilling Solutions



Specific Cleaning Solutions

Focused Cleaning for a Top Performing Sensor

In many applications, electrodes become contaminated from use and produce inaccurate results. Since these contaminants cannot be removed during normal use, special cleaning solutions are needed.

Hanna has prepared a complete line of cleaning and disinfection solutions that eliminate impurities and residues left on electrode surfaces when immersed in special samples, such as wines, musts, oils, soil, industrial solutions, grease, algae, and dairy products.

The Cleaning Solution Series ensures maximum efficiency and accuracy of your sensors when used for its designated application.

Code	Description	Size	Package
HI70630L	acid cleaning solution for meat grease and fats (food industry)	500 mL	bottle
HI70631L	alkaline cleaning solution for meat grease and fats (food industry)	500 mL	bottle
HI70635L	cleaning solution for wine deposits (winemaking)	500 mL	bottle
HI70636L	cleaning solution for wine stains (winemaking)	500 mL	bottle
HI70640L	cleaning solution for milk deposits (food industry)	500 mL	bottle
HI70641L	cleaning and disinfection solution for dairy products (food industry)	500 mL	bottle
HI70642L	cleaning solution for cheese deposits (food industry)	500 mL	bottle

General Use Electrode Cleaning Solutions

Clean the liquid junction of your electrodes once a day or at least once a week to prevent junction clogging and to maintain accuracy. Immerse the electrode in the proper cleaning solution for at least 15-20 minutes.



Code	Application	Size	Package
HI7061L	general purpose	500 mL	bottle
HI7073L	proteins	500 mL	bottle
HI7077L	oil and fats	500 mL	bottle

Electrode Storage Solutions

To minimize junction clogging and ensure fast response time, always keep the glass bulb and the junction of your pH electrode moist. Store the electrode with a few drops of HI70300 storage or pH 4 or pH 7 buffer solution in the protective cap.



Code	Description	Size	Package
HI70300L	electrode storage solution	500 mL	bottle

Electrode Fill Solutions

The electrolyte level in refillable electrodes should be checked before performing any measurement. If the level is low, refill with the proper electrolyte solution to ensure the correct electrode performance. This simple maintenance helps guarantee adequate head pressure to promote efficiency and precision of your refillable electrodes.



Code	Description	Size	Package
HI7071	electrolyte solution, 3.5M KCl + AgCl	30 mL (4)	bottle
HI7072	electrolyte solution, 1M KNO ₃	30 mL (4)	bottle
HI7082	electrolyte solution, 3.5M KCl	30 mL (4)	bottle

ISE Solutions

Electrode	Electrode Code	Page	Ionic Strength Adjusters (ISA) 500 mL bottle	Silver Free Reference Fill Solutions (4) 30 mL bottles	ISE Standards 1, 500 mL bottle	ISE Standards 2, 500 mL bottle	ISE Standards 3, 500 mL bottle	Other
Bromide	HI4102	4	HI4000-00	HI7072, 1 M KNO ₃	HI4002-01, 0.1 M			HI4000-70 polishing strip
Calcium	HI4104	4	HI4004-00	HI7082, 3.5 M KCl	HI4004-01, 0.1 M			HI4104-51 module for combination HI4004-45 conditioning solution
Carbon Dioxide	HI4105	5	HI4005-00	HI4005-40	HI4005-01, 0.1 M	HI4005-03 1000 mg/L (ppm) CO ₂ as CaCO ₃		HI4000-54 replacement pH internal and cap for CO ₂ HI4005-53 CO ₂ membrane kit (3 pack) HI4000-47 4 and 7 pH buffers with chloride background HI4005-45 conditioning solution
Chloride	HI4107	5	HI4000-00	HI7072, 1 M KNO ₃	HI4007-01, 0.1 M	HI4007-02 100 mg/L (ppm)	HI4007-03 1000 mg/L (ppm)	HI4000-70 polishing strip
Iodide	HI4111	21	HI4000-00	HI7072, 1 M KNO ₃	HI4011-01, 0.1 M			HI4000-70 polishing strip
Nitrate	HI4113	27	HI4013-00	HI7078, (NH ₄) ₂ SO ₄	HI4013-01, 0.1 M	HI4013-02 100 mg/L (ppm) nitrate-nitrogen	HI4013-03 1000 mg/L (ppm) nitrate-nitrogen	HI4113-53 module for combination (3 pack) HI4013-06 Interferent suppressant ISA
Potassium	HI4114	40	HI4014-00	HI7076, 1 M NaCl	HI4014-01, 0.1 M			HI4114-51 module for combination
Silver/Sulfide	HI4115	43	HI4000-00 (Ag ⁺) HI4015-00 (S ²⁻)	HI7072, 1 M KNO ₃	HI4015-01 0.1 M Ag ⁺			HI4000-70 polishing strip
Sodium	FC300	43	HI4016-00	HI7079, 2 M NH ₄ Cl + AgCl	HI4016-01, 0.1 M	HI4016-02, 100 mg/L (ppm)	HI4016-03, 1000 mg/L (ppm)	HI4016-45 storage solution HI4016-46 conditioning solution
Reference	HI5315	40		HI7072, 1 M KNO ₃ HI7076, 1 M NaCl HI7078, (NH ₄) ₂ SO ₄ HI7082, 3.5 M KCl				

Phosphate Test Kits

HI3833

The orthophosphate level in mg/L (or ppm) is determined by a colorimetric method. Phosphates can be classified as ortho, condensed or organically bound. As with existing test kits on the market, the Hanna Phosphate Test Kit will only determine orthophosphate levels.

HI38061 with Checker® Disc



Specifications	HI3833	HI38061
Method	colorimetric	checker disc
Range	0-5 mg/L (ppm)	0.00-1.00 mg/L (ppm) 0.0-5.0 mg/L (ppm) 0-50 mg/L (ppm)
Smallest Increment	1 mg/L (ppm)	0.02 mg/L (ppm) 0.1 mg/L (ppm) 1 mg/L (ppm)
Chemical Method	ascorbic acid	ascorbic acid
# Tests	50	100
Ordering Information	<p>HI3833 test kit comes with 20 mL plastic beaker, color comparison cube and 50 packets phosphate reagent.</p> <p>HI38061 test kit comes with 100 packets phosphate reagent, 500 mL deionized water, checker disc, glass vials with caps (2), 3 mL plastic pipette and long plastic pipette.</p>	

HI96713 Phosphate, Low Range Portable Photometer



- CAL Check™
- BEPS (Battery Error Prevention System)
- GLP Features

Specifications	HI96713 Phosphate LR
Range	0.00 to 2.50 mg/L (ppm)
Resolution	0.01 mg/L (ppm)
Accuracy @ 25°C (77°F)	±0.04 mg/L ±4% of reading
Method	adaptation of the ascorbic acid method causes a blue tint in sample
Ordering Information	<p>HI96713 is supplied with sample cuvettes (2) with caps, 9V battery, instrument quality certificate and instruction manual. CAL CHECK™ standards and testing reagents sold separately.</p>
Reagents and Standards	<p>HI96713-11 CAL Check™ standard cuvettes</p> <p>HI93713-01 reagents for 100 tests</p> <p>HI93713-03 reagents for 300 tests</p>

The reagents are in powder and liquid form and are supplied in packets and bottles. The amount of reagent is precisely dosed to ensure the maximum repeatability.

HI4114 Potassium Ion Selective Electrode

For use with compatible
ISE meters

- See a complete list of ISE Solutions on p. 39



Specifications

Type	polymer membrane; combination
Measurement Range	1M to 1X 10 ⁻⁶ M 39100 to 0.039 mg/L (ppm)
Optimum pH Range	1.5 to 12.0
Temperature Range	0 to 40°C
Approximate Slope	+56 mV
Body O.D.	12 mm
Insertion Length	120 mm
Body Material	PEI/PVC
Cable	1 m coaxial
Connection	BNC

Ordering Information

HI4114 polymer membrane; combination ISE with 1m coaxial cable and BNC connection

HI5315 Reference Electrode

For use with
ISE Half-Cells

HI5315 reference electrode is used to complete the electrical circuit and to provide stable reference voltage for ISE half cells.



Specifications

Type	N/A
Measurement Range	N/A
Optimum pH Range	N/A
Temperature Range	0 to 80°C
Approximate Slope	N/A
Body O.D.	12 mm
Insertion Length	120 mm
Body Material	PEI
Cable	1 m coaxial
Connection	BNC

Ordering Information

HI5315 reference electrode with 1m coaxial cable and BNC connection



★ Application Highlight

Potassium in Foods and the Potassium ISE

Potassium is an important component in the diet because it aids in several bodily functions, including muscle growth and contraction, protein production and regulation of fluids, blood pressure and heart rate. Consuming too little potassium can cause fatigue and irritability, while individuals on dialysis or with kidney problems should avoid consuming too much potassium. Potassium-rich foods include several fruits and vegetables, meats, milk, yogurt and nuts. Foods naturally high in potassium, while also low in sodium, have been found to lower the risks of high blood pressure, stroke, kidney stones and bone loss during aging. Recommended daily intake of potassium depends on an individual's age and ranges from 3,000 to 4,700 mg; the FDA established the Daily Value for potassium at 3,500 mg. Potassium can be measured in aqueous solutions with a potassium ion selective electrode (ISE), which operates by potentiometric determination of free potassium ions. Potassium ISEs can be used for a wide range of concentrations, pH values, and temperatures, so they are ideal for use in many applications, especially in the food and beverage industries.



Parameter Highlight

Refractometers

Refractometers provide an effective, easy way to determine salt or sugar content in foods. As light passes through a substance containing salts, sugars and other dissolved solids, it is bent or refracted. An LED light is shone through the sample, which then passes through a prism that is in contact with the solution. The critical angle, the angle where the light is no longer refracted but reflected, is determined by a photodiode light sensor, which in turn determines the solution's refractive index. The refractive index is then converted in a specialized algorithm to sugar/Brix, salt, specific gravity, or other parameter, depending on the desired results units. It is important to note refractometers are not selective: they cannot differentiate between sugar and salt or differentiate types of sugars. Refractometers only measure total concentration of refractive substances. Hanna's digital refractometers measure and compensate for temperature, which highly influences the refractive index of a solution. Automatic temperature compensation (ATC) eliminates the need for a temperature correlation chart and ensures accurate measurement.

These digital refractometers eliminate the uncertainty associated with mechanical refractometers and are ideal for measurements in the field.



HI96800 • HI96801 • HI96802
HI96803 • HI96804

Digital Refractometers

for Sugar Analysis Throughout the Food Industry

- Ideal for the analysis of:
 - Fruits, energy drinks, puddings, soy milk, juices, jam, marmalade, honey, soups, jelly, tofu and condiments
- Dual-level LCD
- ATC (Automatic Temperature Compensation)
- Easy measurement
 - Place a few drops of the sample in the well and press the READ key
- BEPS (Battery Error Prevention System)
- IP65 water protection
- Quick, accurate results
 - Approximately 1.5 second read time
- One-point calibration
 - Calibrate with distilled or deionized water
- Small sample size
 - Sample size can be as small as 2 metric drops
- Automatic shut-off
- Stainless steel sample well
 - Easy to clean and corrosion-resistant
- ABS thermoplastic casing

5 Digital Refractometers to Choose from

HI96800

Measures the **refractive index** in aqueous solutions. Readings can also be displayed with **sucrose temperature compensation** (n_{D20}) or **% Brix**.

HI96801

Measures the refractive index to determine the **% Brix** of sugar in aqueous solutions.

HI96802

Measures the refractive index to determine the **% fructose** in aqueous solutions.

HI96803

Measures the refractive index to determine the **% glucose** in aqueous solutions.

HI96804

Measures the refractive index to determine the **% invert sugar** in aqueous solutions.

Refractive index

These optical instruments employ the measurement of the refractive index to determine parameters pertinent to sugar concentration analysis. The actual measurement of refractive index is quick and provides a standard accepted method for sugar content analysis. Samples are measured after a simple user calibration with deionized or distilled water. Within seconds these instruments measure the refractive index of the sample and convert it to percent by weight concentration units (or % Brix for HI96801 and HI96800). The HI 96800 can display the refractive index directly as well as with sucrose temperature compensation.

Specifications	HI96800	HI96801	HI96802	HI96803	HI96804	
Sugar Content	Range	1.3300 to 1.5080 nD; 1.3330 to 1.5040 nD ₂₀ ; 0.0 to 85.0% Brix (% Brix)	0 to 85% Brix (% Brix)	0 to 85% (by weight) (% fructose)	0 to 85% (by weight) (% glucose)	0 to 85% (by weight) (% invert sugar)
	Resolution	0.1 % Brix; 0.0001 nD; 0.0001 nD ₂₀	0.1 % Brix	0.1	0.1	0.1
	Accuracy (@20°C/68°F)	±0.2% Brix; ±0.0005 nD; 0.0005 nD ₂₀	±0.2% Brix	±0.2%	±0.2%	±0.2%
Temperature	Range	0 to 80°C (32 to 176°F)				
	Resolution	0.1°C (0.1°F)				
	Accuracy (@20°C/68°F)	0.3°C (0.5°F)				
Ordering Information	HI96800, HI96801, HI96802, HI96803 and HI96804 are supplied with 9V battery and instruction manual.					

Making a Standard % Brix Solution

To make a Brix Solution, follow the procedure below:

- Place container (such as a glass vial or dropper bottle that has a cover) on an analytical balance.
- Tare the balance.
- To make an X % brix solution weigh out X grams of high purity sucrose (CAS #: 57-50-1) directly into the container.
- Add distilled or deionized water to the container so the total weight of the solution is 100 g.

Example with 25% Brix:

% Brix	25
g Sucrose	25.000
g Water	75.000
g Total	100.000

Note: Solutions above 60% Brix need to be vigorously stirred or shaken and heated in a water bath. Remove solution from bath when sucrose has dissolved. The total quantity can be scaled proportionally for smaller containers but accuracy may be sacrificed.

HI96821

Digital Refractometer

for Sodium Chloride Measurement Throughout the Food Industry

- Ideal for the analysis of:
 - Salad dressings, cheeses, condiments, pickles, canned foods, jarred foods, milk, juices, energy drinks, soups, brines and whey
- Dual-level LCD
- ATC (Automatic Temperature Compensation)
- Easy measurement
 - Place a few drops of the sample in the well and press the READ key
- BEPS (Battery Error Prevention System)
- IP65 water protection
- Quick, accurate results
 - Approximately 1.5 second read time
- One-point calibration
 - Calibrate with distilled or deionized water
- Small sample size
 - Sample size can be as small as 2 metric drops
- Automatic shut-off
- Stainless steel sample well
 - Easy to clean and corrosion resistant
- ABS thermoplastic casing

These digital refractometers eliminate the uncertainty associated with mechanical refractometers and are ideal for measurements in the field.



Ideal for the food industry

Hanna offers the HI96821 digital sodium chloride refractometer to meet the requirements of the food industry. This optical instrument employs the measurement of the refractive index to determine sodium chloride concentration in aqueous solutions used in food preparation. It is not intended for seawater salinity measurements.

Refractive index

The measurement of refractive index is simple and quick and provides the user an accepted method for sodium chloride analysis. Samples are measured after a simple user calibration with deionized or distilled water. Within seconds the instrument measures the refractive index of the solution. The digital refractometer eliminates the uncertainty associated with mechanical refractometers and is portable for measurements where you need them.

Making a Standard Sodium Chloride Solution

To make a standard NaCl solution (g/100 g), follow the procedure below:

- Place a container (such as a glass vial or dropper bottle that has a cover) on an analytical balance.
- Tare the balance.
- To make an X NaCl solution weigh out X grams of high purity dried Sodium Chloride (CAS #: 7647-14-5; MW 58.44) directly into the container.
- Add distilled or deionized water to the container so the total weight of the solution is 100 g.

Example with g/100 g NaCl:

g/100 g NaCl	10
g NaCl	10.000
g Water	90.000
g Total	100.000

Specifications

	HI96821	
g/100 g	Range	0 to 28
	Resolution	0.1
	Accuracy (@20°C/68°F)	±0.2
g/100 mL	Range	0 to 34
	Resolution	0.1
	Accuracy (@20°C/68°F)	±0.2
Specific Gravity	Range	1.000 to 1.216
	Resolution	0.001
	Accuracy (@20°C/68°F)	±0.002
°Baumé	Range	0 to 26
	Resolution	0.1
	Accuracy (@20°C/68°F)	±0.2
Temperature	Range	0 to 80°C (32 to 176°F)
	Resolution	0.1°C (0.1°F)
	Accuracy (@20°C/68°F)	±0.3°C (0.5°F)

Ordering Information

HI96821 is supplied with battery and instruction manual.

FC300 Sodium Ion Selective Electrode

For use with compatible
ISE meters

- See a complete list of ISE Solutions on p. 39



Specifications

Type	glass; combination
Measurement Range	1.0M to 1X 10 ⁻⁵ M 39100 to 0.039 mg/L (ppm)
Optimum pH Range	9.75 to 14 pH
Temperature Range	0 to 80°C
Approximate Slope	+56 mV
Body O.D.	12 mm
Insertion Length	120 mm
Body Material	glass
Cable	1 m coaxial
Connection	BNC

Ordering Information

FC300 glass; combination ISE with 1m coaxial cable and BNC connection

HI4115 Silver/Sulfide Ion Selective Electrode

For use with compatible
ISE meters

- See a complete list of ISE Solutions on p. 39

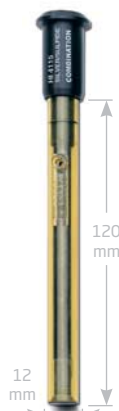

Specifications

Type	solid-state; combination
Measurement Range	Ag ⁺ 1.0M to 1X 10 ⁻⁶ M 107900 to 0.11 mg/L (ppm) S ²⁻ 1.0M to 1X 10 ⁻⁷ M 32100 to 0.003 ppm
Optimum pH Range	Ag ⁺ 2 to 8 S ²⁻ 12 to 14
Temperature Range	0 to 80°C
Approximate Slope	+56 mV Ag ⁺ / -28 mV S ²⁻
Body O.D.	12 mm
Insertion Length	120 mm
Body Material	PEI
Cable	1 m coaxial
Connection	BNC

Ordering Information

HI4115 solid-state; combination ISE with 1m coaxial cable and BNC connection



HI3822 Sulfite Test Kit

The Hanna sulfite test kit makes monitoring easy, quick and safe. The compact size gives the user the versatility to use the kit practically anywhere.

Specifications

Method	titration
Range	0.0-20.0 mg/L (ppm) 0-200 mg/L (ppm)
Smallest Increment	0.2 mg/L (ppm) 2 mg/L (ppm)
Chemical Method	iodometric
# Tests	110 avg.

Ordering Information

HI3822 test kit comes with 30 mL sulfamic acid solution, 30 mL EDTA reagent, 15 mL sulfuric acid solution, 10 mL starch indicator, 120 mL titrant solution, 20 mL calibrated vessel, 50 mL calibrated vessel and calibrated syringe with tip.

Parameter Highlight

Sodium in Foods and Beverages

Sodium is a mineral that is present in many foods and beverages, most commonly in the form of sodium chloride, or salt. Salt occurs naturally in some foods, and it is often added as a flavor enhancer and to prevent spoiling. The addition of salt contributes to the quality of the product, controls the activity of enzymes and regulates water content. A small quantity of sodium is needed in one's diet to aid in bodily functions, but consuming too much sodium poses significant health concerns, such as hypertension and osteoporosis. Hypertension or high blood pressure, can lead to heart disease. Sodium content in packaged foods is monitored by the FDA.

Several instrumental methods are available for determining sodium concentration in foods and beverages. For binary solutions, sodium content can be inferred by measuring salt with a refractometer or an electrical conductivity (EC) meter. For more complex foods and beverages, sodium can be measured directly with a sodium ion selective electrode (ISE), indirectly with a chloride ISE or by potentiometric titration of the chloride ion to infer NaCl. Other methods that directly measure sodium, including inductively coupled plasma mass spectrometry (ICP-MS) and flame atomic absorption spectrophotometry (FAAS) provide highly accurate results at low concentrations, but the sophisticated technology is very expensive.



HI93510 • HI93510N Thermistor Thermometers

- Compact, heavy-duty and waterproof
- Hold feature
- Battery life indicator
- BEPS (Battery Error Prevention System)
- Backlit display (HI93510N only)
- CAL Button (HI93510N only)
 - Allows a simple one-point calibration in an ice bath at 0°C



HI93510 is a waterproof thermometer tailored for the lab and field. The LCD displays the highest and lowest readings in the cycle along with the current temperature. To freeze the reading for easy recording, simply press the HOLD button. Celsius or Fahrenheit range can be selected at the touch of a button.

The HI93510N offers all the features of the HI93510 plus a CAL button to allow calibration of the meter and probe in an ice bath at 0°C. This will assure the removal of the combined meter and probe interchange error. In addition to calibration capabilities, HI93510N has a user-activated backlit display.

A diverse assortment of HI762 probes and cable lengths are available. Probes can be ordered with different handle colors to prevent cross-contamination.

The meter's accuracy can be checked at any time with Hanna calibration keys (see page 49). Simply plug the key into the meter's probe input and if the display value does not match those of the key, the meter is due for recalibration.

Specifications	HI93510	HI93510N
Range	-50.0 to 150.0°C; -58.0 to 302.0°F	
Resolution	0.1°C; 0.1°F (-58.0 to 230.0°F) and 0.2°F (outside)	
Accuracy	±0.4°C; ±0.8°F (for 1 year, excluding probe error)	
CAL Button	N/A	yes
Backlit LCD	N/A	yes
Ordering Information	HI93510 and HI93510N are supplied with HI762BL air/liquid, stainless steel thermistor temperature probe with black handle and 1 m (3.3') cable, 1.5V AA batteries and instructions.	
Optional Probes	HI762 Series, see page 47	

HI9241 Thermistor Thermometer

with Pre-Calibrated Probe

- Compact, heavy-duty and waterproof
- CAL Check™ calibration status alerts
- Missing/damaged probe indicator
- BEPS (Battery Error Prevention System)
- Battery life indicator
- Auto-off after 8 minutes



HI9241 measures a wide range from -50.0 to 150.0°C with exceptional accuracy. This meter is simple to operate and is supplied complete with the user-replaceable HI765PW general purpose penetration probe.

Exchange the probe with any in the HI765 series without requiring recalibration. A diverse assortment of HI765 probes and cable lengths are available. Probes can be ordered with different handle colors to prevent cross-contamination.

The meter's accuracy can be checked at any time with Hanna calibration keys (see page 49). Simply plug the key into the meter's probe input and if the display value does not match those of the key, the meter is due for recalibration.

Specifications	HI9241
Range	-50.0 to 150.0°C
Resolution	0.1°C
Accuracy (@20°C/68°F)	±0.4°C (excluding probe error)
Ordering Information	HI9241 is supplied with HI765PW general purpose/penetration, stainless steel thermistor temperature probe with white handle and 1 m (3.3') cable, 1.5V AAA batteries, instructions and rugged carrying case.
Optional Probes	HI765 Series, see pages 48-49

Parameter Highlight

Temperature

Temperature is an important parameter throughout many stages of the food production process; from manufacturing, to pasteurization, to storage, temperature measurement is essential. There are a variety of thermometer technologies that can be utilized to obtain these temperature measurements. **Thermocouple** thermometers provide a fast response, are capable of measurement at very high temperatures, and provide moderate accuracy. **Thermistor** thermometers offer high accuracy with a moderate response time within a limited temperature range. Hanna offers a variety of thermometers including portables, temperature loggers and application-specific probes for all temperature measuring needs.



HI93503 Thermistor Thermometer

with Pre-Calibrated
Interchangeable Probe

- Compact, heavy-duty, and waterproof
- CAL Check™ calibration status alerts
- Missing/damaged probe indicator
- Hold feature and stability indicator
- BEPS (Battery Error Prevention System)
- Battery life indicator
- Auto-off after 8 minutes

HI93503 measures a wide range from -50.0 to 150.0°C with exceptional accuracy. This meter is simple to operate and supplied with the user-replaceable HI765PWL penetration probe.

Exchange the probe with any other model in the HI765 series without requiring recalibration. A diverse assortment of HI765 probes and cable lengths are available. Probes can be ordered with different handle colors to prevent cross-contamination.

The meter's accuracy can be checked at any time with Hanna calibration keys (see page 49). Simply plug the key into the meter's probe input and if the display value does not match those of the key, the meter is due for recalibration.



HI93501N • HI93501NS Thermistor Thermometers

- Compact, heavy-duty, and waterproof
- CAL Check™ calibration status alerts
- Missing/damaged probe indicator
- Hold feature and stability indicator (HI93501NS)
- BEPS (Battery Error Prevention System)
- Battery life indicator
- Auto-off after 8 minutes

HI93501N is a waterproof thermometer designed for daily use in food applications such as industrial kitchens and catering. The "S" version also adds a stability indicator bargraph and HOLD button to freeze readings on the LCD.

The HI762PWL penetration probe is included. A diverse assortment of HI762 probes and cable lengths are available. Probes can be ordered with different handle colors to prevent cross-contamination.

The meter's accuracy can be checked at any time with Hanna calibration keys (see page 49). Simply plug the key into the meter's probe input and if the display value does not match those of the key, the meter is due for recalibration.



Specifications HI93503

Range	-50.0 to 150.0°C
Resolution	0.1°C
Accuracy	±0.4°C (excluding probe error)
Ordering Information	HI93503 is supplied with HI765PWL penetration, stainless steel thermistor temperature probe with white handle and 1 m (3.3') cable, 1.5V AAA batteries, instructions and hard carrying case.
Optional Probes	HI765 Series, see pages 48-49

Specifications HI93501N • HI93501NS

Range	-50.0 to 150.0°C
Resolution	0.1°C
Accuracy	±0.4°C for 1 year (excluding probe error)
Ordering Information	HI93501N and HI93501NS are supplied with HI762PWL penetration, stainless steel thermistor temperature probe with white handle and 1 m (3.3') cable, 1.5V AAA batteries, instructions and rugged carrying case.
Optional Probes	HI762 Series, see page 47



Application Note

Monitoring Temperature in Confectionaries

In confectionaries, temperature of the sugar syrup will dictate the consistency of the final product. For caramel or other soft candies, the sugar syrup is heated to 250°F (121°C); a brittle hard candy, such as a lollipop, requires the sugar syrup to be heated to 300°F (148°C). A few degrees temperature variation may cause significant differences from one batch to the next. Thermistor thermometers, such as the HI93510N, offer the highest level of accuracy (±0.4°C/0.8°F) over the range of -58.0 to 302.0°F (-50.0 to 150.0°C) with 0.1° resolution for accurate temperature monitoring in the confectionary production process.

HI935005 • HI935005N

K-Type Thermocouple Thermometers

- Hold feature
- Battery life indicator
- BEPS (Battery Error Prevention System)
- Compact, heavy-duty and waterproof
- Backlit display (HI935005N only)
- CAL Button (HI935005N only)
 - Allows a simple one-point calibration in an ice bath at 0°C



HI935005 series meters are waterproof, K-type thermometers offering accurate temperature measurements in a wide range.

These units display current temperature along with the minimum and maximum values achieved during the measuring session on the LCD.

The Hold button freezes the display to allow the user time to record readings. The °C/°F button switches between the Celsius and Fahrenheit temperature scale. The CLEAR button restarts the evaluation of high and low values.

HI935005N features a user-activated backlit for low or no light conditions and a Cal button that allows a simple one-point calibration in an ice bath at 0°C when probe interchange occurs.

Specifications	HI935005	HI935005N
Range	-50.0 to 199.9°C and 200 to 1350°C; -58.0 to 399.9°F and 400 to 2462°F	
Resolution	0.1°C (-50.0 to 199.9°C) and 1°C (outside); 0.1°F (-58.0 to 399.9°F) and 1°F (outside)	
Accuracy	±0.2% F.S. (for 1 year, excluding probe error)	
CAL Button	N/A	yes
Backlit LCD	N/A	yes
Ordering Information	HI935005 and HI935005N are supplied with 1.5V AA batteries, protective case and instructions. HI766 series K-type thermocouple probe not included.	
Optional Probes	HI766 Series, see pages 49-50	

HI935007N

K-Type Thermocouple Thermometer with Penetration Probe

- Compact, heavy-duty and waterproof
- CAL Check™ calibration status alerts
- Damaged probe indicator
- BEPS (Battery Error Prevention System)
- Battery life indicator
- Auto-off after 8 minutes



HI935007N is a portable thermometer that measures temperatures as high as 1350°C. The resolution remains 0.1°C up to 199.9°C and automatically changes to 1.0°C resolution from 200 to 1300°C.

The fixed HI766C penetration probe with 1 m (3.3') flexible cable is also supplied with the instrument.

Advanced battery management features include a display of remaining battery power at startup, low battery warning and BEPS (Battery Error Prevention System), which alerts the user in the event that low battery power could adversely affect readings, as well as auto-shut off capability to preserve battery life.

These features along with a wide measurement range, make HI935007N extremely popular in catering, food preparation and restaurants.

Specifications	HI935007N
Range	-50.0 to 199.9°C; 200 to 1350°C
Resolution	0.1°C (up to 199.9°C); 1°C (outside)
Accuracy	±0.2% full scale (excluding probe error)
Ordering Information	HI935007N is supplied with HI766C penetration, stainless steel K-type thermocouple temperature probe with fixed 1 m (3.3) cable, 1.5V AAA batteries, instructions and hard carrying case.

Application Note

Water Quality in Coffee Brewing

Coffee is one the favorite beverages consumed by billions of people worldwide. Coffee, no matter the brand and quality, can be affected drastically during the brewing stage. The water quality plays a vital role in determining the taste of the beverage. An equally important physical factor is the temperature of the water. Brewing is a chemical reaction between hot water and coffee. Overall, the brewing process extracts compounds from the coffee grounds; how these compounds are extracted is temperature-dependent. Slight variations in temperature affect the taste and aroma of the coffee. Colder water will result in less extraction, leaving the coffee tasting sour, weak and diluted, whereas, water that is too hot will cause over extraction, resulting in bitter and burnt tasting coffee.



HI762 Series HI762 Thermistor Probes

The HI762 temperature probes can be identified by the grey cap on the top of the handle and have the following specifications:

HI762 Probes

Range	-50 to 150°C (-58 to 302°F)
Sensor	NTC thermistor
Accuracy	±0.2°C (±0.4°F)
Probe Handle	ABS
Interchange Error	±0.2°C (±0.4°F)
Probe	AISI 316 stainless steel
Response Time (90% of final value)	6 seconds

The HI762 series with NTC thermistor sensor offers a wide range of probes for measuring liquids, air and gases and for penetration in semi-solids.

Models are available with a 1, 2 or 10 meter cable, and have colored handles for easy identification when measuring different samples.

HI762P

General purpose, penetration probe with colored handle.

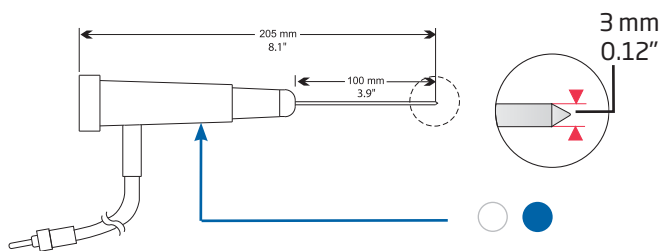

Specifications

1 m (3.3') Cable	2 m (6.6') Cable	Handle Color
HI762PW	-	white
HI762PBL	-	blue

HI762A

Thermistor probe for measuring the temperature of air and gases.

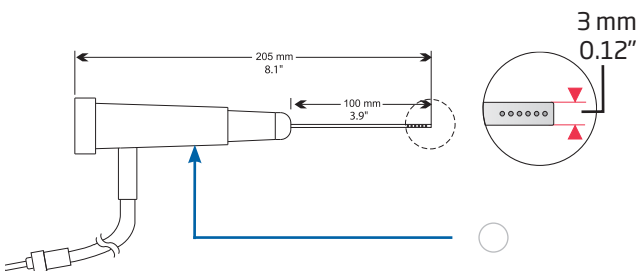

Specifications

1 m (3.3') Cable	2 m (6.6') Cable	Handle Color
HI762A	-	white

HI762PWL

Thermistor probe with sharp tip for penetration of semi-solid samples.

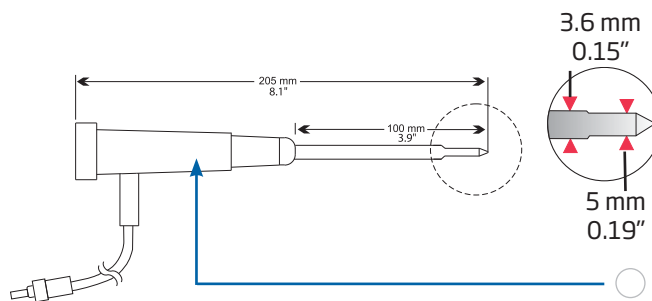

Specifications

1 m (3.3') Cable	2 m (6.6') Cable	10 m (32.8') Cable	Handle Color
HI762PWL	-	-	white

HI762L

Air, liquid probe.

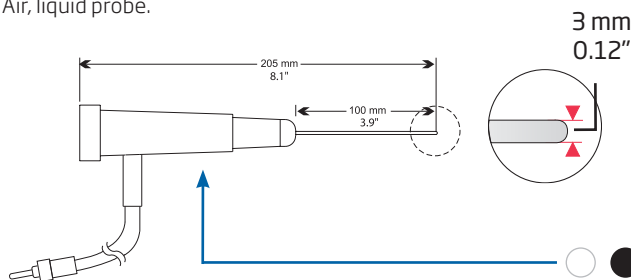

Specifications

1 m (3.3') Cable	2 m (6.6') Cable	10 m (32.8') Cable	Handle Color
HI762L	HI762L/2	HI762L/10	white
HI762BL	-	-	black

HI762W

Wire probe, designed to access hard to reach places. Probe does not incorporate a handle.

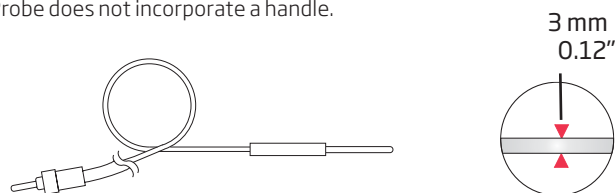

Specifications

1 m (3.3') Cable	2 m (6.6') Cable	10 m (32.8') Cable	Handle Color
HI762W	-	HI762W/10	-

HI765 HI765 Thermistor Probes

The HI765 temperature probes are provided with a PTC thermistor sensor, and have the following specifications:

HI765 Specifications

Range	-50 to 150°C (-58 to 302°F)
Accuracy	±0.2°C (±0.4°F)
Sensor	PTC thermistor
Probe Handle	ABS
Interchange Error	±0.2°C (±0.4°F)
Probe	AISI 316 stainless steel
Response Time (90% of final value)	8 seconds



All probes are pre-calibrated with a maximum error of ±0.2°C (±0.4°F).

The HI765 series can be identified by the white cap on the top of the handle. This series offers a wide range of probes for measuring liquids, air and gases and for penetration in semi-solids.

Models are available with a cable length of 1 to 10 meters and have colored handles for easy identification during measurements of different samples.

HI765P

General purpose, penetration probe with colored handle.

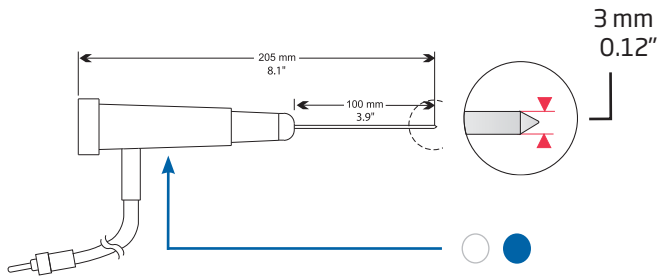

Specifications

1 m (3.3') Cable	10 m (32.8') Cable	Handle Color
HI765PW	HI765PW/10	white
HI765PBL	-	blue

HI765A

Thermistor probe for measuring the temperature of air and gases.

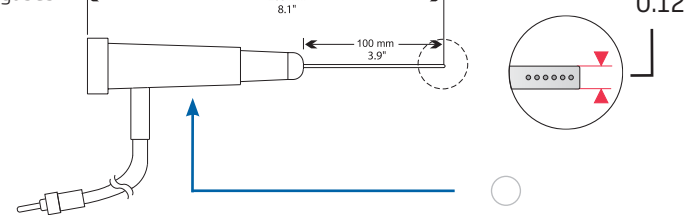

Specifications

1 m (3.3') Cable	10 m (32.8') Cable	Handle Color
HI765A	HI765A/10	white

HI765PWL

Thermistor probe with sharp tip for penetration of semi-solid samples.

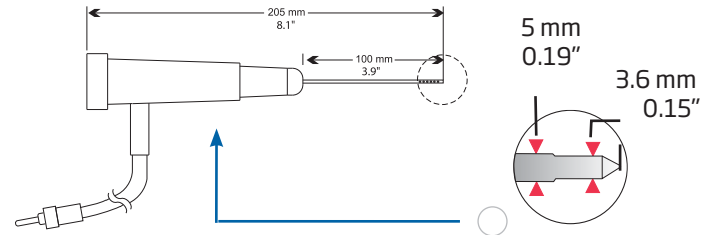

Specifications

1 m (3.3') Cable	2 m (6.6') Cable	Handle Color
HI765PWL	-	white

HI765L

Air, liquid probe.

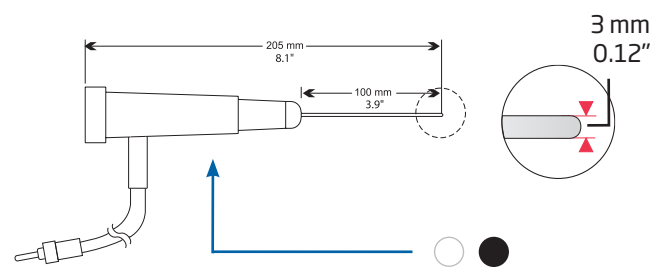

Specifications

1 m (3.3') Cable	10 m (32.8') Cable	Handle Color
HI765L	-	white
HI765BL	-	black

HI765W

Wire probe, designed to access hard-to-reach places. Probe does not incorporate a handle.

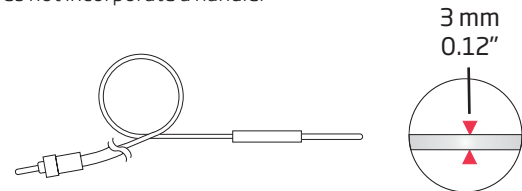

Specifications

1 m (3.3') Cable	10 m (32.8') Cable
HI765W1	-

HI765BP

Thermistor probe without handle, designed to measure the temperature of stacked goods.

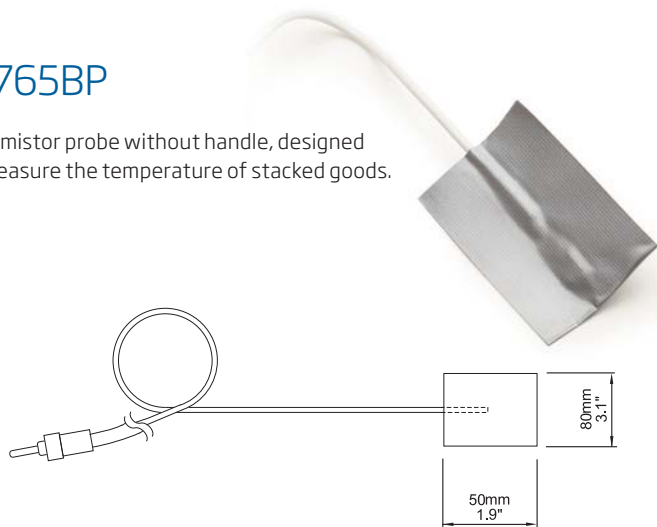

Specifications

1 m (3.3') Cable	2 m (6.6') Cable
HI765BP1	-

HI766

HI766 K-Type Thermocouple Probes

HI766C1, Ultra-Fast Penetration Probe

Penetration probe with fast response time for semi-solid samples.



1 m (3.3') Cable
Mini Connector

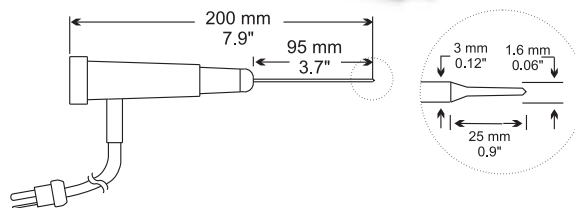

Specifications

Code	Max Temperature	Response Time (90% of final Value)	Probe	Cable Color
HI766C1	300°C (570°F)	4 seconds	stainless steel	green

Calibration Test Keys for Thermistor Thermometers

For measurements that are always reliable, thermometers must be calibrated periodically.

Hanna test keys offer a fast and simple way of checking the accuracy of your instruments.

Connect the key to the probe input. If the reading on the display differs more than 0.4°C (0.8°F) from the key rated value, your thermometer should be recalibrated at our technical service center.



Test Keys for Thermometers Using HI762 Probes

HI762-18C	Test key at -18°C	HI762-004F	Test key at -0.4°F
HI762000C	Test key at 0°C	HI762032F	Test key at 32°F
HI762070C	Test key at 70°C	HI762158F	Test key at 158°F

Test Keys for Thermometers Using HI765 Probes

HI765-18C	Test key at -18°C	HI765-004F	Test key at -0.4°F
HI765000C	Test key at 0°C	HI765032F	Test key at 32°F
HI765070C	Test key at 70°C	HI765158F	Test key at 158°F

For periodic verification of your thermometer's calibration, it is recommended to check at least two points. Choose the test keys with the nominal values closest to the temperature usually measured.

HI766F, High Temperature Probe

Probe with flexible sheath without handle, designed to measure high temperatures.

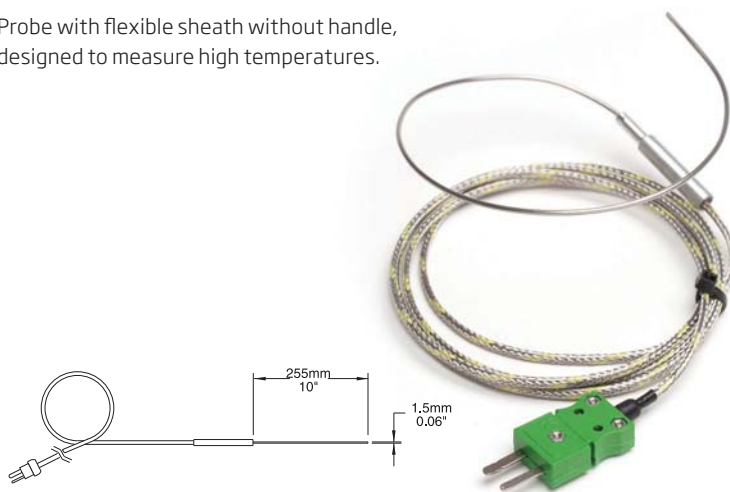

Specifications

Code	Max Temperature	Response Time (90% of final Value)	Probe	Cable Length
HI766F	1100°C (2000°F)	4 seconds	AISI 316 stainless steel	1 m (3.3')



HI766D Probe for Air and Gas

K-type thermocouple probe for measuring the temperature of air and gases.

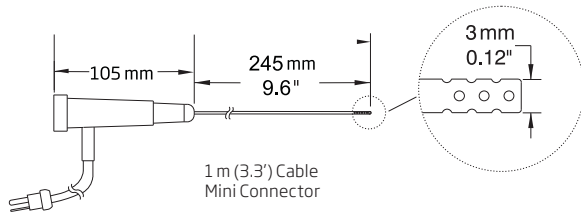

Specifications

Code	Max Temperature	Response Time (90% of final Value)	Probe	Cable Color
HI766D	300°C (570°F)	20 seconds	stainless steel	green



HI766B2, Surface Probe

Probe for measuring the temperature of round surfaces.

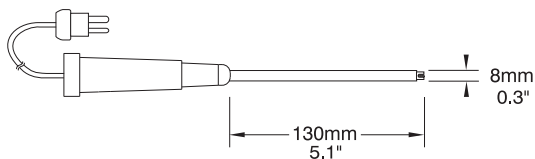

Specifications

Code	Max Temperature	Response Time (90% of final Value)	Probe	Sensor
HI766B2	900°C (1650°F)	3 seconds	stainless steel	spring-loaded

HI98501 Checktemp® Digital Thermometer

with Stainless Steel Penetration Probe



- CAL Check™
 - Automatically verifies calibration at startup and alerts the user of the calibration status.
- °C and °F measurement in one tester
- Easy battery change
- Save battery life with auto shut-off feature
- Large display
- IP65 water resistant protection
- An ideal tool for control in HACCP analysis
- AISI 316 stainless steel penetration probe
- Protective probe sleeve included

Specifications	°C	°F
Range	-50.0 to 150.0°C	-58.0 to 302.0°F
Resolution	0.1°C	0.1°F (58.0 to 199.9°F); 1°F (200 to 302°F)
Accuracy	±0.3°C (-20 to 90°C) ±0.5°C (outside)	±0.5°F (-4 to 194°F) ±1°F (outside)
Ordering Information	HI98501 (Checktemp®) is supplied with stainless steel penetration probe, protective cap, 3VCR2032 Li-ion battery and instructions.	

HI98509 Checktemp®1 Digital Thermometer

with Stainless Steel Probe Attached to a 3.3' Silicone Cable



- CAL Check™
 - Automatically verifies calibration at startup and alerts the user of the calibration status.
- Save battery life with auto shut-off feature
- Ideal for control in HACCP analysis
- Large display
- IP65 water resistant protection
- Silicone probe cable
 - 3.3' silicone cable maintains flexibility and performance in applications where temperatures are widely variable
- AISI 316 stainless steel penetration probe

Specifications	°C	°F
Range	-50.0 to 150.0°C	-58.0 to 302.0°F
Resolution	0.1°C	0.1°F
Accuracy	±0.3°C (-20 to 90°C) ±0.5°C (outside)	±0.5°F (-4 to 194°F) ±1°F (outside)
Ordering Information	HI98509 (Checktemp®1) is supplied with stainless steel probe with 1 m (3.3') silicone cable, 1.5V AAA batteries and instructions.	



HI151 Folding Pocket Thermometer

- CAL Check™ automatically self checks calibration status on startup
- Folding stainless steel penetration probe
- Auto shut-off

The folding Checktemp®4 provides practical temperature measurements for the food service industry.

Special attention was given to the ergonomic form of Checktemp®4. This thermometer fits comfortably and securely in your hand. The LCD on the side of the handle is easy to see and read. The fast responding, fold-away probe is made of high quality, stainless steel and can penetrate semi-frozen and semi-solid foods like meats, ice cream and cheeses. When you are finished using your Checktemp®4, wipe the probe clean and fold it away. Checktemp®4 automatically turns off so you can safely carry it in your pocket.

CAL Check™

As you unfold the stainless steel probe, the Checktemp® 4 automatically turns on and immediately performs a calibration test. This unique Hanna feature, CAL Check™, provides the security of knowing you have accurate measurements. CAL Check™ also lets you know if your battery level is low or if your meter requires recalibration.

Specifications	HI151-00 (Checktemp®4C)	HI151-01 (Checktemp®4F)
Range	-50.0 to 220°C	-58.0 to 428°F
Resolution	0.1°C (-50.0 to 199.9°C); 1°C (200 to 220°C)	0.1°F (-58.0 to 199.9°F); 1°F (200 to 428°F)
Accuracy	±0.3°C ±1 digit (-20.0 to 90.0°C); ±1% F.S. ±1 digit (outside)	±0.5°F ±1 digit (-4.0 to 194.0°F); ±1% F.S. ±1 digit (outside)
Ordering Information	HI151-00 (Checktemp®4 C) is supplied complete with 1.5V AA battery and instructions. HI151-01 (Checktemp®4 F) is supplied complete with 1.5V AA battery and instructions	



HI145 T-Shaped Thermometer

- CAL Check™ automatically self checks calibration status on startup
- Hold button to freeze readings on the display
- Auto shut-off
- Choose from 125 or 300 mm stainless steel probe models
- Choose from °C or °F measurement models

HI145 thermometers were developed for HACCP programs that need high standards of performance with simplicity of use. The durable T-shaped handle fits comfortably in hand and is ideal for applications where applied force is necessary for insertion, such as with incoming meat inspection and semi-frozen foods. The LCD positioned on top of the meter allows for easy reading in cooking applications.

HI145-00 and HI145-01 are equipped with a 125 mm (5") long AISI 316 stainless steel probe. The sharp conical tip provides fast response and improved accuracy over the entire range.

HI145-20 and HI145-30 are supplied with a 300 mm (12") long stainless steel probe, ideal for monitoring hot liquids, such as deep frying and soup preparation.

With an automatic CAL Check™ feature, the HI145 series performs a self-check of its calibration status and displays it on the LCD. This feature ensures accuracy, repeatability and confidence in readings.

Specifications	HI145-00	HI145-20	HI145-01	HI145-30
Probe length	125 x dia 5 mm (4.9" x .2")	300 x dia 5 mm (11.8" x .2")	125 x dia 5 mm (4.9" x .2")	300 x dia 5 mm (11.8" x .2")
Range	-50.0 to 220°C		-58.0 to 428.0°F	
Resolution	0.1°C (-50.0 to 199.9°C); 1°C (200 to 220°C)		0.1°F (-58.0 to 199.9°F); 1°F (200 to 428°F)	
Accuracy	±0.3°C (-20 to 90°C); ±0.4% F.S. (outside)		±0.6°F (-4 to 194°F); ±0.4% F.S. (outside)	
Ordering Information	All models of the HI145 series are supplied complete with 1.5V AAA battery and instructions. HI145-00 with 125 mm probe, HI145-01 with 125 mm probe, HI145-20 with 300 mm probe; HI145-30 with 300 mm probe			



HI98517 KEY® °C KEY® Pocket Thermometer

- Ideal for spot measurements
- Four interchangeable stainless steel probes available

The KEY® is a pocket thermometer with an interchangeable probe for quick spot measurements. With a response time of less than 20 seconds in water, KEY® is ideal for quality control and industrial temperature monitoring.

Four interchangeable temperature probes are available to meet specific requirements. Each probe is constructed out of rugged AISI 316 stainless steel, which resists the harmful effects of chemicals and humidity.

The HI98517-13 probe is for penetration and is included with the meter. It also provides a fast response typical of a thermocouple probe. HI98517-15 and HI98517-30 probes are for general liquid monitoring. The HI98517-12, being a surface probe, is made for machine shops, molding facilities and welding surfaces.



4 probes available:

HI98517-13 (included) penetration/general purpose

K-type thermocouple probe supplied with KEY®.
Application: liquid, air/gas, penetration of semi-solids.

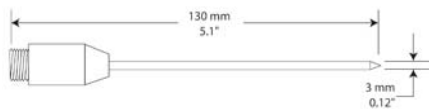

HI98517-15 and HI98517-30 liquid/general purpose

K-type thermocouple probe for KEY®.
Application: liquids, air/gas.

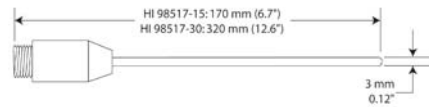

HI98517-12 surface

K-type thermocouple probe for KEY®.
Application: solids, plates, furnaces, molds.



Specifications HI98517 (KEY®C)

Range	-40 to 550°C
Resolution	1°C
Accuracy	±2°C

Ordering Information

HI98517 (KEY®C) is supplied with HI 98517-13 penetration probe, 1.5V batteries and instructions.



HI143-10 T-Logger with Locking Wall Cradle

- Battery life indicator
- Logging start through PC
- Log up to 4,000 samples
- Logging intervals from 1 minute to 24 hours
- Password protected security
- Compact size
 - Measures 60 x 37 x 17 mm (2.4 x 1.5 x 0.7")
- IP65 water resistance

HI143-10 is a temperature data logger with an internal NTC sensor that is controlled via USB or RS232 on a PC with Hanna's Windows® compatible application software. Communication is made between the logger and the PC through the HI143002 with USB connector. The supplied wall cradle makes it easy to lock the meter in place to prevent tampering, and the application software supports security passwords.

Specifications HI143-10

Range	-30. to 70.0°C/-22.0 to 158.0°F
Resolution	0.1°C/0.1°F
Accuracy	±0.4°C (-20 to 60°C); ±0.6°C (outside); ±0.7°F (-4 to 140°C); ±1.1°F (outside)

Ordering Information

HI143-10 is supplied with HI143 logger, HI143002 USB communication cradle, Windows® compatible application software, CR2032 lithium battery, wall cradle, lock and instructions.

HI141 Temperature Dataloggers

- BEPS (Battery Error Prevention System)
- One or two channels with internal or external sensor
- Non-volatile storage of logging
- Waterproof casing
- Compact 86.5 mm (3.4") diameter and 35 mm (1.4") depth

The HI141 series is a family of temperature dataloggers with either one or two channels, internal or external temperature sensors and an optional LCD. External temperature sensor models feature one or two stainless steel sensors on a 1 m (3.3') cable for direct insertion. HI141 can store up to 16,000 temperature samples in a protected, non-volatile EEPROM memory. The logging interval can be set from once per second to once per 24 hour period, and logging delay can be set anywhere up to 199 hours. The MIN or MAX temperature between logging intervals can also be stored. All of your collected data is tamper-proof and stored into serial numbered lots.

HI141000 Windows® compatible software supports communication between the logger and a PC using the HI141001 infrared transmitter.



HI141 without LCD and external sensor

Specifications

	Display	Molded Eye	Sensor(s)	Cable Length* (if applicable)	Range	
Model Specific	HI141AH	•	1 internal	-	-40.0 to 80.0°C / -40.0 to 176.0°F	
	HI141BH	•	1 external	1 m (3.3')	-40.0 to 125.0°C / -40.0 to 257.0°F	
	HI141CH	•	•	1 internal	-	-20.0 to 70.0°C / -40.0 to 158.0°F
	HI141DH	•	•	1 external	1 m (3.3')	-40.0 to 125.0°C / -40.0 to 257.0°F
	HI141EH	•	•	1 internal	-	-40.0 to 80.0°C / -40.0 to 175.0°F
			•	1 external	1 m (3.3')	-40.0 to 125.0°C / -40.0 to 257.0°F
	HI141FH	•	•	2 external	1 m (3.3')	-40.0 to 125.0°C / -40.0 to 257.0°F
	HI141GH	•	•	1 internal	-	-20.0 to 70.0°C / -40.0 to 158.0°F
•			1 external	1 m (3.3')	-40.0 to 125.0°C / -40.0 to 257.0°F	
HI141JH	•	•	2 external	1 m (3.3')	-40.0 to 125.0°C / -40.0 to 257.0°F	

All Models Resolution 0.1°C (-40.0 to 100.0°C); 0.2°C (> 100.0°C) 0.1°F (-40.0 to 190.0°F); 0.3°F (> 190.0°F)

Ordering Information

All HI141 models are supplied with 3.6V Lithium AA battery, HI141 magnetic key and instructions.

Required Accessories

HI141000 Windows® application software (required)
 HI141001 Infrared transmitter (required)



Application Note

Monitoring Refrigerated Trucks

Monitoring temperature of refrigerated trucks is essential during food transport. Chilled meats must remain below 7°C during transport; the temperature of milk must remain below 8°C post pasteurization. Data loggers ensure temperatures in storage and during transport do not exceed quality control and federally regulated temperature limits. Hanna's HI141 temperature loggers are available with internal or external sensors, an LCD for real-time temperature readings and alarm settings for minimum and maximum temperatures. An indicating red LED will alert the user at a glance if the temperature exceeds an alarm setting at any point during a logging period, allowing for easy quality control monitoring.

HI902C Automatic Titration System

- Installation and method optimization support available
- Flexibility to measure acidity, salt, ascorbic acid and more
- Linear and dynamic dosing
- Fixed or equivalence endpoints
 - Choice of endpoint detection: equivalence point (1st or 2nd derivative) or fixed pH/mV value
- Clip-Lock™ exchangeable burette system
 - allows burette exchange in a matter of seconds
- Transfer methods and reports to a PC or another titrator via USB flash drive
- Two sensor inputs with the addition of a second analog board
- RS232 port for direct connection to an analytical laboratory balance
- Potentiometric titrator additional features
 - Linked titration methods allow two methods to run in sequence (acidity and salt)
 - Acid-base, non-aqueous, redox, complexometric, precipitation, back titrations and titre determination can be performed
 - Supports up to 100 titration methods (standard and user-defined)
 - Supplied with a standard methods pack or customizable user methods
 - Titration graph can be displayed on-screen and saved as a bitmap
 - Reminders for titrant age and standardization expiration
 - Multiple equivalence endpoint titrations with multiple molecular weights and reaction ratios
 - Supports two burette dosing pumps with the ability to perform back titrations
 - 5, 10 or 25 mL precision ground glass syringe with PTFE plunger
 - 40,000 step screw drive, piston dosing pump
 - 3-way motor driven valve
 - PTFE burette tubing with polyurethane tube jacketing
- Full featured research grade pH meter
 - ATC (Automatic Temperature Compensation)
 - Up to five calibration points with automatic recognition of standard buffers
 - Calibrate with up to five custom buffers
- mV (ORP) meter
 - Relative mV calibration
- ISE meter
 - Numerous concentration units including: mol/L, mmol/L, mg/L, mg/mL, µg/L, %, ppt, ppm, g/L and user-defined
 - Up to five calibration points with five custom standards



Powerful Customization, Accurate Analysis

The HI902C is an automatic titrator that complements our wide range of products dedicated to quick and accurate laboratory analysis. HI902C can perform acid-base, redox, complexometric, precipitation, back titrations and titre determinations.

The HI902C dispenses the titrant, detects the endpoint and performs all necessary calculations automatically.

This versatile titrator supports up to 100 standard or user-defined methods. When powered on, the instrument initiates an internal diagnostics check and then readies itself for the first titration of the day. A large color LCD screen clearly shows the chosen method and related information. A real-time titration curve can be shown on the display; this feature is useful when new methods are tested or when a procedure needs to be optimized. At the end of the titration, the data is automatically stored (manual storage option for the graph) and can be transferred to a flash drive or PC by USB connection.

This titrator is supplied with a pack of standard methods or you can create your own. Methods (standard or user) can be created, stored or edited with the Hanna PC software and then transferred to the titrator by USB flash drive. Software updates can also be performed using a USB flash drive as well.

Users can connect pH, ORP or ISE electrodes to the HI902C, as well as create a complete workstation with a PC, monitor, keyboard and printer.

The HI902C complies with GLP specifications. All GLP information from each sample can be stored, including ID number, date and time of analysis, electrode ID code and last calibration date.

Clip-Lock™ Exchangeable Burette System

With Clip-Lock™, it only takes a few seconds to exchange the reagent burettes to perform a different titration. No need to purge, clean and refill.



Specifications

HI902C

mV	Range	-2000.0 to 2000.0 mV
	Resolution	0.1 mV
	Accuracy (@25°C/77°F)	±0.1 mV
	Calibration	single-point offset
pH	Range	-2.000 to 20.000 pH
	Resolution	0.1, 0.01, 0.001 pH
	Accuracy (@25°C/77°F)	±0.001 pH
	Calibration	up to five-point calibration, eight standard buffers and five custom buffers
ISE	Range	1 x 10 ⁻⁶ to 9.99 x 10 ¹⁰
	Resolution	1, 0.1, 0.01
	Accuracy (@25°C/77°F)	±0.5% monovalent; ±1% divalent
	Calibration	up to five-point calibration, seven standard solutions and five user-defined standards
Temperature	Range	-5.0 to 105.0°C; 23 to 221°F; 268.2 to 378.2 K
	Resolution	0.1°C; 0.1°F; 0.1K
	Accuracy (@25°C/77°F)	±0.1°C; ±0.4°F; ±0.2K
	Calibration	up to five-point calibration, seven standard solutions and five user-defined standards
Other Specifications	Burette Sizes	5, 10, and 25 mL
	Burette Resolution	1/40000
	Display Resolution	0.001 mL
	Dosing Accuracy	±0.1% of full burette volume
	Display	5.7" (320 x 240 pixel) backlit color LCD
	Methods	Load up to 100 methods (standard and user-defined)
	Burette Auto-Detection	burette size is automatically recognized when inserted into the unit
	Programmable Stirrer	propeller type, 100-2500 RPM, automatically held within 10% of the set value, resolution 100 rpm
	Flow Rate	User-selectable from 0.1 mL/min to 2 x burette volumes/min
	Temperature Compensation	manual (MTC) or automatic (ATC)
	Endpoint Determination	equivalence point (1st or 2nd derivative) or fixed pH/mV value
	Potentiometric Titrations	acid-base (pH or mV-mode), redox, precipitation, complexometric, non-aqueous, ion-selective, argentometric, back titrations, and titre determination
	Measurement Units	user-specified expression of concentration units to suit specific calculation requirements
	Real Time & Stored Graphs	mV-volume or pH-volume titration curve, 1st derivative curve or 2nd derivative curve pH-mode, mV-mode or ISE mode: pH/mV/concentration values versus time-datalogging results
	Data Storage	up to 100 titration and pH/mV/ISE reports
	USB Host (Side)	flash drive compatibility for transfers of methods and reports
	Peripherals (Rear)	connections for VGA display, PC-keyboard, parallel printer, USB device input, RS232, interface for auto-sampler
GLP Conformity	instrumentation data storage and printing capabilities	
Ordering Information	HI902C1-01 (115V): titrator with one analog board, stirrer with stand, 25 mL glass burette, dosing pump drive, temperature sensor, USB cable, 256 Mb USB flash drive and PC software.	
	HI902C2-01 (115V): titrator with two analog boards, stirrer with stand, 25 mL glass burette, dosing pump drive, temperature sensor, USB cable, 256 Mb USB flash drive and PC software.	

Accessories

Code	Description	Code	Description
HI900100	dosing pump	HI900260	3-way valve (includes 3 gaskets and 2 screws)
HI900125	25 mL burette assembly (includes syringe, aspiration, and dispensing tubes)	HI900270	aspiration tube with fitting (includes blue protection tube, gasket, and tube lock)
HI900110	10 mL burette assembly (includes syringe, aspiration, and dispensing tubes)	HI900280	dispensing tube with fitting (includes standard dispensing tip, blue protection tube, gasket, and tube lock)
HI900105	5 mL burette assembly (includes syringe, aspiration, and dispensing tubes)	HI900301	overhead stirrer assembly (includes overhead stirrer and 3 propellers)
HI900225	25 mL burette syringe	HI900302	propeller (includes 3 propellers)
HI900210	10 mL burette syringe	HI900310	overhead electrode holder (includes overhead stirrer without electronics and stir bar)
HI900205	5 mL burette syringe	HI900320	stirrer stand

Versatile Data Management

- HI902C can be easily incorporated into any existing GLP data management program:
 - Easily record all necessary GLP information with every sample, such as sample identification, company and operator name, date, time, electrode ID codes and calibration information
- Data can be transferred to a USB flash drive or PC with the Hanna HI900PC application software
- The USB port allows for the easy transfer of methods, reports and software upgrades via USB flash drive
- Users can print reports of analyses directly from the titrator
- An external monitor and keyboard can be attached for added versatility



- Customizable Reports
 - Titration reports are fully customizable



- Titration Reports
 - Titration or pH/mV/ISE results can be viewed on-screen or transferred to a USB flash drive or PC



- Titration Graphs
 - Titration graphs can be viewed on-screen or saved as images and transferred along with titration report

HI84529

Titratable Acidity Mini Titrator and pH Meter

for the Dairy Industry

- **Piston-driven pump with dynamic dosing**
 - For highly accurate, repeatable results
- **CAL Check™**
 - Alerts users to potential problems during calibration such as contaminated buffers or dirty electrodes
- **Log-on-demand**
 - Log data up to 400 samples (200 for titration; 200 for pH/mV)
- **Graphic mode/exportable data**
 - Displays in-depth data on titration, which can then be stored and exported to either a USB drive or PC using the USB connection
- **Automatic stirrer speed control**
 - Maintains stirrer speed at approximately 600 rpm regardless of viscosity of solution
- **GLP features**
 - Meets Good Laboratory Practices
- **Application-specific FC260B half-cell pH electrode**
 - This electrode is designed to measure all types of dairy related products
- **HI5315 double junction half-cell reference electrode**
 - Features a plunger design to clear any clogging of the outer junction
- **Automatic or manual temperature compensation**

The HI84529 is an easy to use, fast and affordable mini automatic titrator and pH meter designed for testing acidity levels in dairy products. This new generation of mini automatic titrator improves upon the titrant delivery system and measuring ranges for increased accuracy compared to previous models. This meter reflects Hanna's years of experience as a manufacturer of analytical instruments.

This mini titrator includes a pre-programmed analysis method designed for acidity measurements for dairy analysis. It uses a powerful algorithm which analyzes the electrode response in order to determine when the titration reaction has reached completion. By simply pressing the START key, the HI84529 automatically performs an end point titration and displays results immediately in a choice of units.

Acidity Measurement and its Significance in the Dairy Industry

There are two fundamentally different measurements of dairy products: titratable acidity and pH. The pH is a measurement of hydrogen ion concentration while titratable acidity is the neutralizing capacity of a dairy product by a base.

An increase in acidity can be caused by bacteria formation. Monitoring acidity is a way of determining the quality and freshness of dairy products. Acidity is determined by a fixed pH end point titration using sodium hydroxide (a base), and is defined as the consumption of base necessary to shift the pH value from 6.6 (corresponding to fresh milk) to a pre-determined pH value. While pH 7.0 is the actual point of neutralization, phenolphthalein is commonly employed as a color indicator to determine the end point of reaction and with it, color change occurs at pH 8.3. Titratable acidity is expressed in a variety of units based on the one which reflects the titration method and strength of base used during titration.



Specifications	HI84529	
Titratable Acidity Titrator	Low Range	%I.a.: 0.01 to 0.20; °SH: 0.4 to 8.9; °D: 1.0 to 20.0; °TH: 1.1 to 22.2
	High Range	%I.a.: 0.1 to 2.0; °SH: 4.4 to 88.9; °D: 10 to 200; °TH: 11.1 to 222.2
	Low Range Resolution	%I.a.: 0.01; °SH: 0.1; °D: 0.1; °TH: 0.1
	High Range Resolution	%I.a.: 0.1; °SH: 0.1; °D: 1; °TH: 0.1
	Accuracy Low Range (@25°C/77°F)	± 0.01 %I.a.
	Accuracy High Range (@25°C/77°F)	± 0.1 %I.a.
	Titration Method	acid-base titration
	Sample Size LR 20	20 mL or 20 g
	Sample Size LR 50	50 mL or 50 g
	Sample Size HR 20	20 mL or 20 g
pH Meter	Principle	endpoint titration, adjustable (pH 8.1 - 8.4 in 0.1 increments)
	Pump Speed	10 mL/min
	Stirring Speed	800 (Low Range) / 1000 (High Range)
	Range	-2.0 to 16.0 pH / -2.00 to 16.00 pH
mV Meter	Resolution	0.1 pH / 0.01 pH
	Accuracy (@25°C/77°F)	±0.01 pH
	Calibration	one, two or three-point calibration four available buffers (pH 4.01, 6.00, 8.30, 10.01)
Temperature	Range	-2000.0 to 2000.0 mV
	Resolution	0.1 mV
	Accuracy	± 1.0 mV
Ordering Information	Range	-20.0 to 120.0°C; -4.0 to 248.0°F; 253.1 to 393.2 K
	Resolution	0.1°C; 0.1°F; 0.1 K
	Accuracy	±0.4°C; ±0.8°F; ±0.4 K
<p>HI84529-01 (115V) is supplied with HI84529-70 Reagent Kit for titratable acidity in dairy products, FC260B pH electrode with 1 m (3.3') cable, HI5315 reference probe with 1 m (3.3') cable, HI7662-M stainless steel temperature probe with 1 m (3.3') cable, HI7072 fill solution (30 mL), HI700640 cleaning solution for milk deposits (2 x 20 mL), One capillary dropper pipette, Two 100 mL beakers, Tube set (aspiration tube with titrant bottle cape and dispensing tube with tip), Dosing Pump Valve, 5 mL Syringe, 1 mL plastic pipette, stir bar, power adapter, and instruction manual.</p>		



HI84532

Titrateable Acidity Mini Titrator and pH Meter

for Fruit Juice

- **Piston-driven pump with dynamic dosing**
 - For highly accurate, repeatable results
- **CAL Check™**
 - Alerts users to potential problems during calibration such as contaminated buffers or dirty/broken electrodes
- **Log-on-demand**
 - Log data up to 400 samples (200 for titration; 200 for pH/mV)
- **Graphic mode/exportable data**
 - Displays in-depth data on titration, which can then be stored and exported to either a USB drive or PC using the USB connection
- **Automatic stirrer speed control**
 - Maintains stirrer speed at approximately 600 RPM regardless of viscosity of solution
- **Meets Good Laboratory Practices**
- **Intuitive design with large keys and easy to navigate screens**
- **Dedicated HELP key**
- **pH/mV meter**
- **Automatic or manual temperature compensation**

The HI84532 digital automatic mini titrator and pH meter is designed for measuring the concentration of titrateable hydrogen ions contained in fruit juice samples by neutralization with a strong base solution to a fixed pH as according to the Official Methods of Analysis of AOAC International.

Specifications

HI84532

Titrateable Acidity Titrator	Low Range, 5mL sample	g/100 mL as citric acid: 0.10 to 1.20% CA; g/100 mL as tartaric acid: 0.11 to 1.41% TA; g/100 mL as malic acid: 0.10 to 21.26 %MA
	High Range, 5mL sample	g/100 mL as citric acid: 0.80 to 10.00% CA; g/100 mL as tartaric acid: 0.94 to 11.70% TA; g/100 mL as malic acid: 0.84 to 10.50% MA
	Resolution	0.01%
	Accuracy (@25°C/77°F)	3% of reading or ± 0.02% @25°C citric acid whichever is greater
	Titration Method	acid-base titration
	Principle	endpoint titration: 8.1 pH
	Pump Speed	10 mL/min
pH Meter	Stirring Speed	600 rpm
	Range	-2.0 to 16.0 pH / -2.00 to 16.00 pH
	Resolution	0.1 pH / 0.01 pH
	Accuracy (@25°C/77°F)	±0.01 pH
mV Meter	Calibration	one, two or three-point calibration; four available buffers (pH 4.01; 7.01; 8.20, 10.01)
	Range	-2000.0 to 2000.0 mV
	Resolution	0.1 mV
Temperature	Accuracy	± 1.0 mV
	Range	-20.0 to 120.0°C; -4.0 to 248.0°F; 253.1 to 393.2 K
	Resolution	0.1°C; 0.1°F; 0.1 K
Ordering Information	Accuracy (@25°C/77°F)	±0.4°C; ±0.8°F; ±0.4 K
	HI84532-01 (115V) is supplied with HI84532-70 Reagent Kit for titrateable acidity in fruit juice, HH1131B glass body pH electrode with BNC connector and 1 m (3.3') cable, HI7662-T stainless steel temperature probe with 1 m (3.3') cable, HI7082 electrode fill solution (30 mL), two 100 mL beakers, One 20 mL beakers, tube set (aspiration tube with titrant bottle cap and dispensing tube with tip), dosing pump valve, 5 mL Syringe, 1 mL plastic pipette, stir bar, power adapter, and instruction manual.	

Parameter Highlight

Acidity in Food and Beverages

Acidity in food and beverages is an important factor for the taste and composition of many products. Different from pH, which simply indicates whether a substance is an acid or a base, acidity indicates the concentration of the acid in the solution. The acidity of a substance is determined by titration; a base of a known concentration is added to a sample until all acids in the sample have been reacted with. The total acidity is typically expressed as the predominant acid. For example, the predominant acid in orange juice is citric acid. The AOAC Method 942.15 is commonly used to measure the titrateable acidity various fruit products to a pH endpoint of pH 8.1. The AOAC Method 947.05 is used to determine the acidity of milk, which is reported as % lactic acid. This method specifies using a phenolphthalein color indicator or a pH electrode and meter to determine a pH endpoint of pH 8.2 or pH 8.3. The advantages of utilizing a pH electrode over a phenolphthalein color indicator are that color changes are subjective, especially when working with an opaque sample such as milk. Utilizing a pH meter or automatic titration system provides improved accuracy and repeatability for acidity determinations in food and beverages.

HI903 Karl Fischer Volumetric Titrator

for Moisture Determination

- **Precision titrant delivery system**
 - 40,000 step piston dosing pump
 - Accurate to 0.1%
 - Delivers as little as 0.125 μL of titrant
 - Precision ground, 5 mL glass burette with PTFE plunger, PTFE burette tubing, and polyurethane tube jacketing (thermally insulating, light blocking)
 - Clip-Lock™ exchangeable burette system enables users to exchange reagent burettes in a matter of seconds
- **Sealed solvent system**
 - Change to fresh solvent in a matter of seconds without opening the titration vessel
 - Minimizes exposure to ambient humidity which reduces titrant consumption and saving time
 - PTFE solvent tubing is resistant to harsh KF solvents and titrants
- **Beaker top**
 - Chemically-resistant reaction vessel cap and fittings
 - Quick-remove sample port plug with replaceable silicone rubber septum for solid or liquid sample introduction
- **Glass anti-diffusion burette dispensing tip**
 - Delivers titrant in high turbulence zone, ensuring rapid reaction
 - Prevents unwanted diffusion of titrant into solvent
- **Built-in stirrer**
 - Automatic, integrated magnetic stirrer adjustable from 200-2000 RPM
 - Optical feedback for automatic speed control
 - Optional external magnetic stirrer available
- **Rechargeable indicating desiccant**
 - Prevents the ingress of ambient humidity into the sealed solvent system while maintaining full titrator functionality
 - Minimizes changes to titrant titre
 - Indicates when adsorption capacity is depleted
 - Regenerated at 150°C
- **PTFE bottle cap**
 - Caps fit any GL45-threaded bottle
 - Chemically-resistant caps and fittings
 - Removable desiccant cartridges
- **Titrant database**
 - Stores standardization information for up to 20 titrants
 - Standardization reminders



Measures 100 ppm to 100% water content

- Supports up to 100 titration methods (standard and user defined)
- **Dynamic dosing with optional pre-dispensing**
 - Faster titration without sacrificing accuracy
- **Results displayed directly in the selected units**
- **Titration graph can be displayed on-screen and saved as a bitmap**
- **Multi-language support**
- **Incorporates into any GLP data management program:**
 - Easily record all necessary GLP information with every sample, including company and operator name, date, time, electrode ID codes and standardization information
- **Compatible with most major brands of Karl Fischer reagents**
- **Proper mixing of titrant and analyte**
 - Digital, magnetic stirring system with optical feedback
 - Conical titration cell to facilitate mixing over a wide volume range
 - Upward dispensing of titrant to ensure rapid reaction
- **Flexible, accurate detection of the titration endpoint**
 - Dual platinum pin polarization electrode for bivalentammetric indication
 - Signal averaging reduces noise
 - Selectable endpoint criteria: fixed mV persistence, relative drift stop or absolute drift stop
- **USB flash drive input**
 - Transfer methods, reports and graphs to either a PC or other HI903 titration system
 - Field upgradable software
- **Balance interface**
 - Automatically acquire sample mass via serial RS232 interface
- **Easy to operate**
 - User friendly interface
 - Context-sensitive help screens
 - Self-diagnostic features for external components including dosing pump, burette and stirrer
- **Ideal for food and beverage, nutraceutical, and chemical manufacturing**

Moisture in Guar Gum

Guar, or cluster bean, is a high temperature and drought tolerant annual legume whose endosperm is used to manufacture guar gum. In the food industry, the thickening, binding and emulsifying qualities of guar gum have made it a sought after product in the international food market. Commercial guar gum can contain up to 12% moisture as impurity; clarified guar gum, which is dissolved in water, precipitated and washed with alcohol, generally contains slightly less moisture. The moisture content of guar gum can be measured with Hanna's HI903 Karl Fischer titrator.

Specifications	HI903	
Titration	Range	100 ppm to 100%
	Resolution	1 ppm (0.0001%)
	Result Units	%, ppm, mg/g, µg/g, mg, µg, mg/mL, µg/mL, mg/pc, µg/pc
	Sample Type	liquid or solid
Determination	Pre-Titration Conditioning	automatic
	Background Drift Correction	automatic or user-selectable value
	Endpoint Criteria	fixed mV persistence, relative drift stop or absolute drift stop
	Dosing	dynamic with optional pre-dispensing rate
	Result Statistic	mean, standard deviation
Clip Lock™ Exchangeable Burette System	Dosing Pump Resolution	1/40000 of the burette volume (0.125 µL per dose) with 5 mL burette
	Dosing Pump Accuracy	±0.1% of full burette volume
	Syringe	5 mL precision ground glass with PTFE plunger
	Valve	motor-driven 3-way, PTFE liquid contact material
	Tubing	PTFE with light block and thermal jacketing
	Dispensing Tip	glass, fixed position, anti-diffusing
	Titration Vessel	conical with operation volume between 50-150 mL
	Solvent Handling System	sealed system, integrated diaphragm air pump
Electrode	Type	HI76320D dual platinum pin, polarization electrode
	Connection	BNC
	Polarization Current	1, 2, 5, 10, 15, 20, 30 or 40 µA
	Voltage Range	2 mV to 1000 mV
	Voltage Resolution	0.1 mV
	Accuracy (@25°C/77°F)	±0.1%
Stirrer	Type	magnetic, optically regulated, digital stirrer
	Speed	200-2000 rpm
	Resolution	100 rpm
Peripheral Devices	PC	easily view, transfer, print or delete methods and reports via HI900PC application
	USB Flash Drive	easily upgrade software or transfer methods and reports between devices using a USB drive
	Laboratory Analytical Balance	RS232 to connect any laboratory balance
	Printer	print directly from the HI903 to a printer via parallel port
	Monitor	instrument status and titrations can be viewed on a larger screen using any VGA-compatible external monitor
	Keyboard	alphanumeric text can be entered using an optional PS/2 keyboard
Ordering Information	HI903-01 (115V) is supplied with HI76320 dual platinum pin electrode, dosing pump, 5 mL burette assembly with tubing, air pump assembly with tubing, beaker and bottle top assemblies and all fittings, desiccant cartridges (4) with indicating desiccant, stir bar, waste bottle, calibration key, USB cable, power cable, HI900PC application, USB flash drive, quality certificate, ISO 8655 burette compliance report and instruction manual binder.	

Versatile Data Management

- HI900 Series titration systems can be easily incorporated into any existing GLP data management program
- Easily record all necessary GLP information with every sample, such as sample identification, company and operator name, date, time, electrode ID codes and calibration information
- Data can be transferred to a PC using the Hanna HI900PC software application
- The USB port allows for the easy transfer of methods, reports and software upgrades via USB flash drive
- Users can print reports of analyses directly from the titrator
- An external monitor and keyboard can be attached for added versatility



- Customizable reports
 - Titration reports are fully customizable



Clip-Lock™ Exchangeable Burette System

The Clip-Lock™ exchangeable burette system prevents cross contamination while reducing loss of time and reagents. Simply slide out the burettes, detach the aspiration tube from the titrant bottle, and detach the dispensing tube from the sample cell for quick exchanges.

HI904 Karl Fischer Coulometric Titrator for Moisture Determination

- Precision dosing system by generator electrode
 - 400 mA pulsed current
 - Available with or without a diaphragm
- Molecular sieve desiccant
 - Prevents the ingress of ambient humidity into the sealed solvent system while maintaining full titrator functionality
 - Regenerated at 300°C
- Sealed generator cell
 - Generator electrode
 - Dual pin bivoltammetric platinum sensing electrode
 - Molecular sieve desiccant cartridge
 - Replaceable septum for liquid sampling port
 - Accessory port
- Built-in stirrer
 - Automatic, integrated magnetic stirrer adjustable from 200-2000 RPM
 - Optical feedback for automatic speed control
 - Extra optional port for external stirrer
- Sealed solvent system
 - Change to fresh reagent in a matter of seconds without opening titration vessel
 - Minimizes exposure to ambient humidity
 - PTFE tubing is resistant to harsh KF chemicals
 - Sealed tube holder to collect PTFE tube after exchanging reagent
- PTFE bottle cap
 - Caps fit any GL45-threaded bottle
 - Chemically-resistant caps and fittings
 - Removable desiccant cartridges



Measures 1 ppm to 5% water content

The HI904 Karl Fischer Coulometric Titrator for samples with low moisture content. The HI904 combines an ultra-high electrolytically generated iodine dynamic dosing system with optically-regulated magnetic stirring, sophisticated endpoint determination and background drift correction algorithms.

The HI904 applies a pulsed DC current for titrant generation, detects the endpoint and performs all necessary calculations automatically.

The HI904's powerful software and intuitive menus are easily navigated on the large, color LCD display, making it simple to view results. Choose from included methods or develop a custom method for almost any application or sample type.

- Supports up to 100 methods (standard and user-defined)
- Results displayed directly in the selected units
- Titration graph can be displayed on-screen and saved as an image to be transferred to a PC or printed
- USB flash drive input
 - Transfer methods, reports and graphs to a PC or other titration system
 - Field upgradable software
- Incorporates into any GLP data management program
 - Easily record all necessary GLP information with every sample, including company and operator name, date, time, electrode ID codes and standardization information
- Proper mixing of reagent and sample
 - Digital, magnetic stirring system with optical feedback
 - Adjustable stirring speed to facilitate mixing
- Flexible, accurate detection of the titration endpoint
 - Dual platinum pin polarization electrode for bivoltammetric detection of endpoint
- Multi-language support
- Balance interface
 - Automatically acquire sample mass via RS232 serial interface
- Easy to operate
 - User-friendly interface
 - Contextual help screens

 Parameter Highlight

Moisture in Food

Moisture content regulates the shelf life of food and is important to measure in both the product and the packaging materials. Regularly monitoring moisture content ensures efficiency and optimum quality in processed foods. Hanna offers Karl Fischer Titrators for moisture determination in foods and beverage products. Hanna offers the HI903 Volumetric Karl Fischer Titrator for samples with up to 100% water and the HI904 Coulometric Karl Fischer Titrator for samples with water content less than 5%. With an average time per test less than 5 minutes, Karl Fischer Titrators provide a solution for timely quality control testing in house, eliminating the cost and waiting time associated with outside laboratory results. Karl Fischer Titrators are able to quickly, accurately and efficiently determine the moisture content in food products.



- **Fritted (Diaphragm) Generator**
 - Anode/analyte and cathode/catholyte separated by glass diaphragm
 - Prevents anode-generated iodine from being reduced to iodide at the cathode
 - Ideal for extremely low H₂O content, high accuracy demand, nitrogenous compounds, easily reduced samples



- **Fritless (No Diaphragm) Generator**
 - Uses one easy to replace Karl Fischer reagent
 - Lower and more stable drift rates
 - Easier cleaning of generator cell

Specifications	HI904	
Titration	Range	1 ppm to 5%
	Resolution	0.1ppm (0.0001%)
	Result Units	%, ppm, ppt, mg/g, µg/g, mg, µg, mg/mL, µg/mL, mg Br/100g, g Br/100g, mg Br, g Br
	Sample Type	liquid or solid (external dissolution / extraction)
	Titration Vessel	operating volume between 100 - 200 mL
Generator Electrode	Reagent Handling System	sealed system with integrated diaphragm air pump and beaker adapter
	Configuration	fritted or fritless (with or without diaphragm)
	Current Control	automatic or fixed (400 mA)
Determination	Electrode Type Detection	automatic
	Pre Titration Conditioning	automatic
	Background Drift Correction	automatic; user-selectable value
	Endpoint Criteria	fixed mV persistence, relative drift stop, or absolute drift stop
	Dosing	dynamic with three speed settings
Detector Electrode	Result statistic	mean, standard deviation
	Type / Connection	dual platinum pin, polarization electrode / BNC connector
	Polarization Current	1, 2, 5, or 10 µA
	Voltage Range	2 mV to 1100 mV
	Voltage Resolution	0.1 mV
Peripheral Devices	Accuracy (@25°C/77°F)	±0.1%
	PC	easily view, transfer, print or delete methods and reports via HI900 PC application
	USB Flash Drive	easily upgrade software or transfer methods and reports between devices using a USB drive
	Laboratory Analytical Balance	RS232 to connect a laboratory analytical balance
	Printer	print directly from the HI904 to a parallel port printer
	Monitor	instrument status and titrations can be viewed on a larger screen using any VGA compatible external monitor
Ordering Information	Keyboard	alphanumeric text can be entered using an optional PS/2 keyboard
	HI904D-01 (with diaphragm) (115V) and HI904-01 (115V) are supplied with dual platinum pin electrode, air pump assembly, titration vessel assembly (glass vessel, accessory port stopper, sample port cap and septum, stir bar, desiccant, desiccant cartridge, fittings), vessel support with adapter, pump locking screw with plastic head, reagent bottle assembly (bottle cap, desiccant, desiccant cartridge, fittings, tubing (silicone and PTFE)), water bottle assembly (waste bottle, bottle cap, desiccant, desiccant cartridge, fittings, tubing (silicone and PTFE)), calibration key, reagent exchange adapter, accessory holder assembly, joint grease, Karl Fischer generator electrode (removable generator electrode cable), USB cable, USB storage device, HI900 PC application software, power adapter, quality certificate and instruction manual binder.	

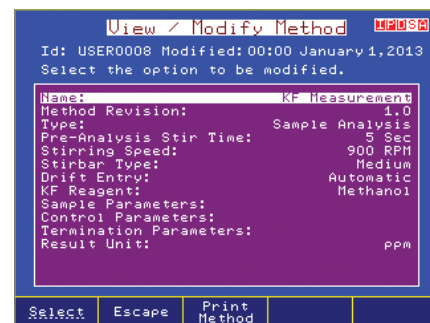

Versatile Data Management

- HI900 Series titration systems can be easily incorporated into any existing GLP data management program
- Easily record all necessary GLP information with every sample, such as sample identification, company and operator name, date, time, electrode ID codes and calibration information
- Data can be transferred to a PC using the Hanna HI900PC software application
- The USB port allows for the easy transfer of methods, reports and software upgrades via a USB flash drive
- Users can print reports of analyses directly from the titrator using a standard parallel printer
- An external monitor and keyboard can be attached for added versatility

HI921 Autosampler

Automate up to 18 samples

The HI921 Autosampler is an automated titration sample handling system designed for use with the HI902C Potentiometric Titration System. This high quality system makes the titration of multiple samples quick and easy.

With the Autosampler, up to 18 samples can be run consecutively. The HI921 Autosampler interfaces directly with the HI902C to access titration methods. Once a method is established, the user can then customize the automation sequence of their samples for this method. Sample names and size can be customized or auto-filled with preset values. Once the Autosampler sequence is complete, two reports are available for review: a sequence report, with a table outlining each sample name, beaker position, sample size and result for the tray, and a detailed titration report for each individual sample, including the graph of the titration data.

- Flexible, accurate detection of the titration endpoint with HI902C potentiometric titrator
- Automation of up to 18 samples per tray
 - 16 and 18 sample trays available based on beaker size required.
 - 16 sample tray holds 150 mL beakers
 - 18 sample tray holds 100 mL beakers
- Absolute encoder in sample tray
 - The Autosampler always knows the tray position without the need to "home" or calibrate
- Electrode rinse feature
 - Up to 3 beakers per tray can be designated for electrode dip rinses; a primary, secondary and tertiary rinse
- Automatic addition of reagents or deionized water to the sample beaker by peristaltic pump
- Included control panel for manual operation of motors and pumps
- Built-in magnetic stirrer or optional overhead propeller stirrer
- Barcode reader interface for easy sample tracking
 - USB barcode reader interface for easy sample identification
- Built-in RFID in each tray, communicating tray serial number and number of beakers present
- Optical IR beam detects presence or absence of beakers in the tray
 - Ensures the HI921 does not proceed with titration if a beaker is missing
- USB interface
 - Use with barcode reader
 - Field upgradable software
- Sample trays made of chemically-resistant materials are removable, easy to clean and dishwasher safe.
- Electrode holder can accommodate 3 x 12 mm electrodes, temperature sensor, 1 aspiration tube and 5 multipurpose tubes (reagent addition, burette dosing)
 - Switch between methods without having to physically switch electrodes
- Real-time progress of the sequence and results shown on the HI902 titrator screen
- Integrated peristaltic (up to 3) and one membrane pump (optional)
- Sample leveling feature
 - Automatic leveling for fast preparation of volumetric samples
- Waste removal feature
 - Aspirate completed samples into a waste container



Specifications	HI921
Electrode Holder Slots	3 x 12-mm electrodes
	1 temperature sensor
	1 aspiration tube
	5 multi - purpose slots (titrant/reagent tubes)
Temperature Sensor	HI7662-A (included)
Stirrers	built-in magnetic stirrer
	overhead propeller stirrer (optional)
Peristaltic Pumps	up to 3 can be installed
	installs in slots #1, 2, 3
Membrane Pump (for cleaning)	installs in slot #4
Trays	16 beakers x 150 mL (HI920-11660)
	18 beakers x 100 mL (HI920-11853)
	built-in RFID, transmits the tray type and serial number to HI921
Beakers	ASTM short-form glass beakers
	HI920-060 (150 mL), fits HI920-11660 tray - 16 plastic beakers
	HI920-053 (100 mL), fits HI920-11853 tray - 18 plastic beakers
Control Panel	buttons for manual operation of tray
	manual operation of peristaltic or membrane pumps
	2-line backlit display with status information
Barcode Reader	compatible with USB barcode readers, used to add sample names
Report Storage	up to 40 trays of samples (e.g.: 720 reports for 18-beaker tray)

Ordering Information	Choose your Autosampler configuration:		
	x=	1	16 sample tray
		2	18 sample tray
	y=	0	no peristaltic pump
		1	one peristaltic pump
		2	two peristaltic pumps
	z=	3	three peristaltic pumps
		0	no membrane pump
		1	one membrane pump

HI 921 – x y z



HI88703 Precision Turbidity Benchtop Meter

EPA Compliant

- Two measuring ranges
- GLP features
- Log up to 200 measurements
- On-screen contextual help
- Up to five-point turbidity calibration
- PC connectivity via USB
- Backlit LCD

The HI88703 provides reliable and accurate readings on low turbidity ranges.

Specifications	HI88703	
Non-Ratio Mode	Range	0.00 to 9.99; 10.0 to 40.0 NTU; 0.0 to 99.9; 100 to 268 Nephelos; 0.00 to 9.80 EBC
	Resolution	0.01; 0.1 NTU; 0.1; 1 Nephelos; 0.01 EBC
Ratio Mode	Range–Ratio Mode	0.00 to 9.99; 10.0 to 99.9; 100 to 4000 NTU 0.0 to 99.9; 100 to 26800 Nephelos 0.00 to 9.99; 10.0 to 99.9; 100 to 980 EBC
	Resolution–Ratio Mode	0.01; 0.1; 1 NTU; 0.1; 1 Nephelos; 0.01; 0.1, 1 EBC
Additional Specifications	Range Selection	automatic
	Accuracy @25°C/77°F	±2% of reading plus 0.02 NTU (0.15 Nephelos; 0.01 EBC) ±5% of reading above 1000 NTU (6700 Nephelos; 245 EBC)
	Repeatability	±1% of reading or 0.02 NTU (0.15 Nephelos; 0.01 EBC) whichever is greater
	Method	Nephelometric method (90°) or Ratio Nephelometric Method (90° & 180°), adaptation of the USEPA Method 180.1 and Standard Method 2130 B
	Measuring Mode	normal, average, continuous
	Turbidity Standards	<0.1, 15, 100, 750 and 2000 NTU
	Calibration	two, three, four or five-point calibration
	Ordering Information	HI88703-01 (115V) is supplied with sample cuvettes and caps (5), calibration cuvettes, silicone oil (HI93703-58), tissue for wiping cuvettes, power cord and instruction manual.
Reagents and Standards	HI 88703-11 Turbidity calibration standards (<0.1, 15, 100, 750 and 2000 NTU)	



HI98703 Turbidity Meter

Fast Tracker™ Technology, EPA Compliant

- Four-point calibration
- USB and RS232 PC connectivity
- Log up to 200 records
- GLP features–Meets Good Laboratory Practices
- User-friendly, backlit display
- Battery life indicator

FastTracker™ 
location traceability



Fast Tracker™ Tag Identification System

Easily install iButton® tags near your sampling points for quick iButton® readings. Each tag contains a computer chip with a unique identification code encased in stainless steel. You can install a practically unlimited amount of tags.

Specifications	HI98703
Range	0.00 to 9.99; 10.0 to 99.9 and 100 to 1000 NTU
Range Selection	automatic
Resolution	0.01 NTU from 0.00 to 9.99 NTU; 0.1 NTU from 10.0 to 99.9 NTU; 1 NTU from 100 to 1000 NTU
Accuracy @25°C/77°F	±2% of reading plus 0.02 NTU
Repeatability	±1% of reading or 0.02 NTU, whichever is greater
Method	ratio nephelometric method (90°), ratio of scattered and transmitted light; adaptation of the USEPA Method 180.1 and Standard Method 2130 B
Measuring mode	normal, average, continuous
Turbidity Standards	<0.1, 15, 100 and 750 NTU
Calibration	two, three or four-point calibration
Ordering Information	HI98703-01 (115V) is supplied with sample cuvettes and caps (5), HI98703-11 calibration cuvettes, HI93703-58 silicone oil, cuvette cleaning cloth, 1.5V AA batteries, AC adapter, instruction manual and rugged carrying case.



We Design, Manufacture, Supply and Support All of Our Products.

When you buy a Hanna product, you're not only buying the best value for your money, but you're also receiving the benefit of Hanna's unsurpassed customer service and post-sale technical support.

With 60 offices in over 40 countries, Hanna dedicates itself to be a worldwide leader in service and selection.

Offering research grade quality at competitive prices, every Hanna office strives to work with each customer to develop a solution tailored to their needs, and within their budget.

Hanna Instruments, USA
Highland Industrial Park
584 Park East Drive,
Woonsocket, RI 02895

p: 877-MY-HANNA
(877-694-2662)
f: (401) 765-7575
e: sales@hannainst.com
w: www.hannainst.com



www.hannainst.com